

## • Rounding Mixed Numbers

### Power Up

#### facts

Power Up J

#### mental math

- Estimation:** Andrea estimated that each story of the tall building was 12 feet tall. Andrea counted 30 stories in the building. What would be her estimate for the overall height of the building?
- Number Sense:** Simplify the fractions  $\frac{10}{3}$ ,  $\frac{10}{4}$  and  $\frac{10}{5}$ .
- Geometry:** The three angles of the equilateral triangle each measure  $60^\circ$ . What is the total measure of the three angles?
- Measurement:** Caleb jogged a distance of 1 mile and then walked 200 feet. Altogether, how many feet did Caleb jog and walk?
- Powers/Roots:**  $6^2 + 14$
- Probability:** If the chance of rain is 10%, what is the chance that it will not rain?
- Calculation:**  $50\%$  of 50,  $+ 50$ ,  $+ 2$ ,  $\div 7$ ,  $+ 3$ ,  $\div 7$
- Roman Numerals:** Compare 19 ○ XXI

#### problem solving

Choose an appropriate problem-solving strategy to solve this problem.

The multiples of 7 are 7, 14, 21, 28, 35, and so on. We can use multiples of 7 to help us count days of the week.

Seven days after Monday is Monday. Fourteen days after Monday is Monday again. So 15 days after Monday is just 1 day after Monday. What day is 30 days after Monday? ... 50 days after Saturday? ... 78 days after Tuesday?

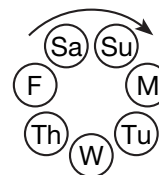

## New Concept

### Thinking Skill

#### Discuss

Where is  $7\frac{1}{4}$  on the number line?  
Where is  $7\frac{1}{8}$ ?

The mixed number  $7\frac{3}{4}$  is between 7 and 8. To round  $7\frac{3}{4}$  to the nearest whole number, we decide whether  $7\frac{3}{4}$  is nearer 7 or nearer 8. To help us understand the question, we can use this number line:

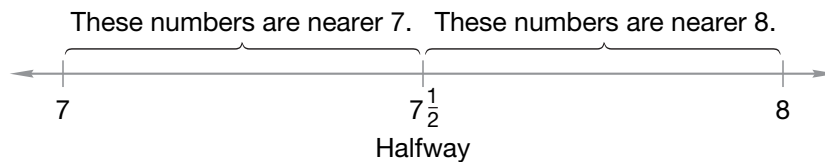

We see that  $7\frac{1}{2}$  is halfway between 7 and 8. Since  $7\frac{3}{4}$  is between  $7\frac{1}{2}$  and 8, we know that  $7\frac{3}{4}$  is nearer 8 than 7. This means  $7\frac{3}{4}$  rounds up to 8.

### Example 1

**J.D. had  $6\frac{2}{5}$  yards of rope. Estimate the length of rope he had by rounding  $6\frac{2}{5}$  to the nearest whole number.**

The mixed number  $6\frac{2}{5}$  is between 6 and 7. We need to decide whether it is nearer 6 or nearer 7. The number  $6\frac{1}{2}$  is halfway between 6 and 7. The number  $6\frac{2}{5}$  is less than  $6\frac{1}{2}$  because the numerator of  $\frac{2}{5}$  is less than half the denominator. So we round  $6\frac{2}{5}$  down to **6**.

**Verify** Explain why  $6\frac{3}{5}$  is closer to 7 than 6.

### Example 2

**Kylie estimated the area of this rectangle as 45 square inches. Did Kylie make a reasonable estimate?**

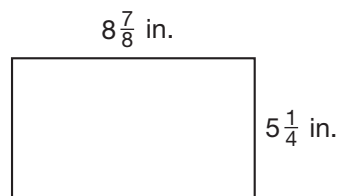

We round  $8\frac{7}{8}$  inches to 9 inches, and we round  $5\frac{1}{4}$  inches to 5 inches. Then we multiply.

$$A = l \times w$$

$$A = 9 \text{ in.} \times 5 \text{ in.}$$

$$A = 45 \text{ sq. in.}$$

We find that **Kylie's estimate is reasonable.**

### Example 3

Estimate the perimeter of a rectangular picture frame that is  $15\frac{1}{8}$  inches long and  $10\frac{3}{4}$  inches wide.

We round  $15\frac{1}{8}$  inches to 15 inches, and we round  $10\frac{3}{4}$  inches to 11 inches.

$$P = 2l + 2w$$

$$P = 2(15 \text{ in.}) + 2(11 \text{ in.})$$

$$P = 30 \text{ in.} + 22 \text{ in.}$$

$$P = 52 \text{ in.}$$

The perimeter of the frame is **about 52 inches**.

### Lesson Practice

Round each mixed number to the nearest whole number:

a.  $3\frac{2}{3}$

b.  $7\frac{1}{8}$

c.  $6\frac{3}{5}$

d.  $6\frac{1}{4}$

e.  $12\frac{5}{6}$

f.  $25\frac{3}{10}$

g. Estimate the product of  $9\frac{4}{5}$  and  $5\frac{1}{3}$ .

h. Estimate the sum of  $36\frac{5}{8}$  and  $10\frac{9}{10}$ .

i. Estimate the perimeter of the rectangle in Example 2.

### Written Practice

*Distributed and Integrated*

- \*1. (97) There were 60 deer and 40 antelope at the drive-thru safari. What was the ratio of deer to antelope at the drive-thru safari?
  
2. (53, 74) If a side of a regular octagon is 25 centimeters long, then the perimeter of the octagon is how many meters?
  
- \*3. (28) What year was five decades before 1826?
  
4. (86) **Multiple Choice** Which number is  $\frac{3}{4}$  of 100?  
A 3                      B 25                      C 50                      D 75

5. Write the length of this line segment as a number of millimeters and as a number of centimeters.

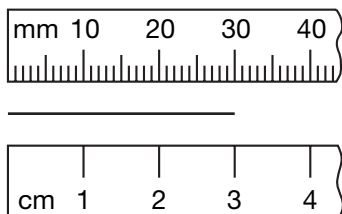

6. If the segment in problem 5 were cut in half, then each small segment would be how many centimeters long?

7. **Estimate** Is \$8.80 closer to \$8 or to \$9? Explain why.

- \*8. Estimate the difference when  $7\frac{3}{4}$  is subtracted from  $18\frac{7}{8}$ .

9. The kite was at the end of 240 feet of string. How many yards are equal to 240 feet of string?

10.  $AB$  is 60 mm.  $BC$  is half of  $AB$ .  $CD$  is one third of  $AB$ . Find  $AD$ .

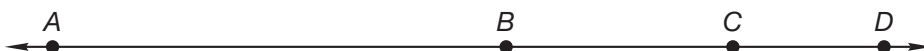

\*11.  $4 + 8.57 + 12.3$

\*12.  $16.37 - 12$

13.  $\begin{array}{r} \$3.58 \\ \times 10 \\ \hline \end{array}$

14.  $24^2$

\*15.  $\frac{4300}{25}$

\*16.  $14w = \$20.16$

17.  $\sqrt{9} + \sqrt{16}$

- \*18. **Analyze** Write fractions equal to  $\frac{5}{6}$  and  $\frac{1}{4}$  that have denominators of 12. Then subtract the smaller fraction from the larger fraction.

\*19.  $6\frac{3}{5} + 1\frac{3}{5}$

20.  $8\frac{5}{6} - 1\frac{1}{6}$

21.  $\frac{2}{10} \times \frac{5}{10}$

\*22.  $2 \div \frac{4}{5}$

23.  $\frac{9}{50} = \frac{\square}{100}$

- 24.** Use the information below to answer parts **a** and **b**.

(Inv. 5,  
99)

Becky ran two races at the track meet. She won the 100-meter race with a time of 13.8 seconds. In the 200-meter race, she came in second with a time of 29.2 seconds.

- a.** In the 200-meter race, the winner finished 1 second faster than Becky. What was the winning time?
- b.** Becky earned points for her team. At the track meet first place earns 5 points, second place earns 3 points, and third place earns 1 point. How many points did Becky earn?

- 25.** Reduce:  $\frac{50}{100}$

(90)

- 26.** Write the coordinates of points *A*, *B*, and *C*.

(Inv. 8)

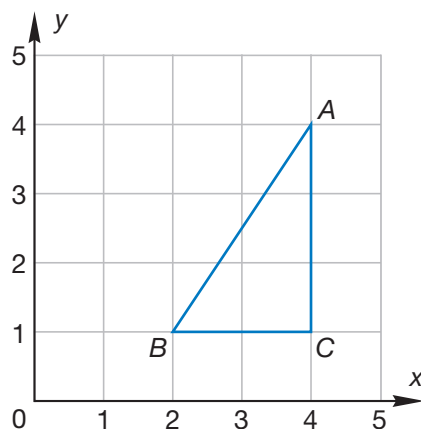

- 27.** Alexis has run the 100-meter race five times. Her times in seconds are listed below. What is the median of Alexis's 100-meter race times?

(84)

14.0, 13.8, 13.7, 13.9, 14.1

- 28.** A square-foot floor tile is 12 inches on each side. One square foot is how many square inches?

(72)

- \*29.** Use an inch ruler to find the length and width of this rectangle. Then calculate the perimeter of the rectangle.

(44, 53)

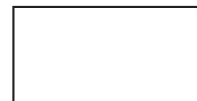

- \*30.**  **Explain** Franco estimates that he has read  $\frac{7}{10}$  of a book. What is a reasonable estimate of the fraction of the book that Franco has not read? Explain how you found your answer.

(41)

## • Subtracting Decimal Numbers Using Zeros

### Power Up

#### facts

Power Up J

#### mental math

- a. **Estimation:** Megan purchased  $5\frac{4}{5}$  pounds of fruit at the grocery store. She bought  $1\frac{7}{8}$  pounds of apples and  $1\frac{3}{4}$  pounds of oranges. Using compatible numbers, about how many pounds of fruit did Megan buy that were not apples or oranges?
- b. **Measurement:** One kilogram is about 2 pounds 3 ounces. About how many pounds and ounces is 2 kilograms?
- c. **Number Sense:** Simplify the fractions  $\frac{4}{6}$ ,  $\frac{8}{6}$ , and  $\frac{9}{6}$ .
- d. **Geometry:** The three angles of the triangle measure  $58^\circ$ ,  $62^\circ$ , and  $60^\circ$ . What is the total measure of the three angles?
- e. **Powers/Roots:**  $\sqrt{100} - 3^2$
- f. **Probability:** Kurt labeled the six sides of a cube with the letters  $A, B, C, C, C,$  and  $D$ . If Kurt tosses the cube once, what is the probability that it will land with a  $C$  facing up?
- g. **Calculation:**  $\frac{1}{3}$  of 15,  $\times 2, + 2, \times 2, \div 3, + 1, \div 3, \div 3$
- h. **Roman Numerals:** Compare: XXIX  $\bigcirc$  30

#### problem solving

Choose an appropriate problem-solving strategy to solve this problem. If two standard number cubes are rolled, many pair combinations are possible. Here are some of the possible combinations:

(1, 1), (1, 2), (1, 3), (1, 4), (1, 5), (1, 6),  
(2, 2), (2, 3), (2, 4), (2, 5), (2, 6)

List the rest of the possible combinations. In all, how many combinations are possible?

## New Concept

### Thinking Skill

#### Verify

How many zeros can we place to the right of the last digit of a decimal number and not change the value of the number?

For some subtraction problems, we need to add decimal places to perform the subtraction. If we subtract 0.23 from 0.4, we find there is an “empty” place in the problem.

$$\begin{array}{r} 0.4\_ \leftarrow \text{empty place} \\ - 0.23 \\ \hline \end{array}$$

We fill the empty place with a zero. Then we subtract.

$$\begin{array}{r} 0.\overset{3}{\cancel{4}}\overset{1}{0} \\ - 0.23 \\ \hline 0.17 \end{array}$$

### Example 1

**A Brand X computer completed a task in 0.4 seconds. A Brand Y computer completed the same task in 0.231 fewer seconds. What length of time did the Brand Y computer take to complete the task?**

To find the time difference, we subtract. We set up the problem by lining up the decimal points, remembering to write the first number on top. We fill empty places with zeros. Then we subtract. Brand Y completed the task in **0.169 seconds**.

$$\begin{array}{r} 0.\overset{3}{\cancel{4}}\overset{9}{0} \\ - 0.231 \\ \hline 0.169 \end{array}$$

**Justify** How can you check the answer?

### Example 2

**A pedometer measures the distance a person has walked. Jayna is walking 3 kilometers to Rochelle’s house. While waiting at a crosswalk, Jayna notices that her pedometer reads 1.23 kilometers. What distance does Jayna still need to walk to arrive at Rochelle’s house?**

This problem is similar to subtracting \$1.23 from \$3. We place the decimal point to the right of the 3, fill the decimal places with zeros, and subtract.

$$\begin{array}{r} 3.\overset{2}{\cancel{0}}\overset{1}{0} \\ - 1.23 \\ \hline 1.77 \end{array}$$

**Connect** What would the answer be if it were a money amount?

### Example 3

In 2004 the land area of Laredo, Texas, was 83.44 square miles. In 1993 the land area was 44 square miles. Between 1993 and 2004, the city of Laredo added about how many square miles?

The number 83.44 is between 83 and 84. We choose the compatible number 84 and subtract.

$$84 \text{ sq. mi} - 44 \text{ sq. mi} = 40 \text{ sq. mi}$$

Laredo added **about 40 square miles** between 1993 and 2004.

### Lesson Practice

Subtract:

a.  $0.3 - 0.15$

b.  $0.3 - 0.25$

c.  $4.2 - 0.42$

d.  $3.5 - 0.35$

e.  $10 - 6.5$

f.  $6.5 - 4$

g.  $1 - 0.9$

h.  $1 - 0.1$

i.  $1 - 0.25$

j.  $2.5 - 1$

k. Anisa poured 1.2 liters of cranberry juice from a full 2-liter container. How much cranberry juice was left in the container? Show your work.

l. The land area of Long Beach, California, is 50.4 square miles. The land area of Jersey City, New Jersey, is 14.9 square miles. About how much greater is the land area of Long Beach? Explain why your estimate is reasonable.

### Written Practice

*Distributed and Integrated*

- 1. Represent** (31, 45) Draw two parallel segments that are horizontal. Make the upper segment longer than the lower segment. Connect the endpoints of the segments to form a quadrilateral. What kind of quadrilateral did you draw? Now draw the figure again rotated  $90^\circ$  clockwise.
- \*2.** (77, 85) "A pint's a pound the world around" means that a pint of water weighs about a pound. About how much does a gallon of water weigh?



\*3. **Estimate** Estimate the sum of  $7\frac{1}{5}$  and  $3\frac{7}{8}$  by rounding both numbers to the nearest whole number before adding.  
(101)

\*4. **Analyze** There are 43 people waiting in the first line and 27 people waiting in the second line. If some of the people in the first line move to the second line so that there are the same number of people in each line, then how many people will be in each line? Does your answer represent the mean, median, mode, and/or range of the data?  
(84)

5. If  $25m = 100$ , then  $m^2$  equals what number?  
(78)

6. **Represent** Name the shaded part of this square as a decimal number, as a reduced fraction, and as a percent.  
(71)

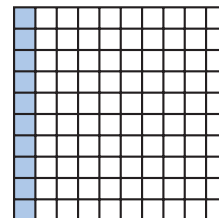

7. **Analyze** Write fractions equal to  $\frac{1}{5}$  and  $\frac{7}{8}$  that have denominators of 40. Then add the fractions. Remember to convert the answer to a mixed number.  
(75, 79)

8. Compare: one tenth  ten hundredths  
(68, 69)

9. The first four multiples of 2 are 2, 4, 6, and 8. What are the first four multiples of 6?  
(15)

10. The rectangle at right was made with nails that are 1 inch long.  
(53)



a. The length of the rectangle is about how many inches?

b. The perimeter of the rectangle is about how many inches?

\*11. In a recent year, the United States produced 76.7 million bushels of wheat, which was 32.8 million bushels more than France produced. That year, how many million bushels of wheat did the United States and France produce altogether?  
(49, 73)

\*12.  $0.4 - 0.12$   
(102)

\*13.  $6.2 - 0.71$   
(102)

14.  $315$   
(6)

15.  $9 \times \$4.36$   
(17)

16.  $540 \times 780$   
(56)

4197

17.  $\frac{432}{6}$   
(26)

18.  $\frac{864}{12}$   
(92)

586

92

+ 3634

19.  $5 - \left(1\frac{2}{3} + 1\frac{2}{3}\right)$   
(63, 75)

20.  $\frac{5}{6} \times \left(3 \times \frac{2}{5}\right)$   
(76)

\*21.  $2 \div \frac{1}{3}$   
(96)

\*22.  $\frac{1}{3} \div 2$   
(96)

23.  $\frac{12}{50} = \frac{\square}{100}$   
(79)

24. This graph shows how Darren spends his time each school day. Use the information in this graph to answer parts **a** and **b**.  
(Inv. 7)

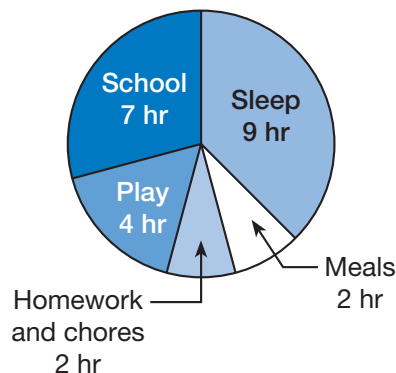

- a. What is the total number of hours shown in the graph?  
b. What fraction of the day does Darren spend sleeping?

- \*25. Kande poured 1.4 liters of juice from a full 2-liter container. How much juice was left in the container?  
(102)

- \*26. **Conclude** Write the next four terms of this counting sequence:  
(Inv. 4)

..., 2.5, 2.8, 3.1, 3.4, \_\_\_\_\_, \_\_\_\_\_, \_\_\_\_\_, \_\_\_\_\_, ...

27. How many blocks were used to build this rectangular solid?  
(18)

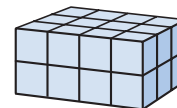

- \*28. (Inv. 9) A fruit stand sells pineapples, strawberries, and kiwis. Fruit purchases over a two-day period are recorded in the table below.

Fruit	Number Sold
Pineapples	23
Strawberries	16
Kiwis	41

Estimate the probability that someone who purchases a piece of fruit buys a pineapple.

- \*29. (69) Arrange these numbers in order from least to greatest:

$$1.0, \frac{1}{10}, 0.001, \frac{1}{100}$$

- \*30. (Inv. 7) This table shows the number of wins for five football teams in their first season:

First Season

Team	Wins
Yellowjackets	2
Eagles	5
Brahmas	3
Panthers	5
Tigers	1

- a. Choose an appropriate type of graph for the data, and then graph the data.
- b.  **Formulate** Write two questions that can be answered using your graph.



Brett's batting average this year is 0.300. Last year his average was 0.279.

- a. What is the difference between his average last year and his current average?
- b. Nathan's batting average this year is 0.009 lower than Brett's. What is Nathan's batting average?

• **Volume**

**Power Up**

**facts**

**mental math**

**problem solving**

Power Up J

- a. **Number Sense:** Simplify the fractions  $\frac{9}{8}$ , and  $\frac{12}{8}$ .
- b. **Measurement:** The 1600-meter relay is a race in which 4 runners each run an equal “leg” of the race. How many meters long is each leg?
- c. **Measurement:** On November 11, 1911, the temperature in Oklahoma City set a record high for the date at  $83^{\circ}\text{F}$ . By midnight, the temperature had dropped 66 degrees to set a record low for the date. What was the low temperature?
- d. **Geometry:** What is the area of a square that is 5 inches on each side?
- e. **Estimation:** Choose the more reasonable estimate for the length of your index finger: 6 centimeters or 6 inches.
- f. **Powers/Roots:**  $10^2 - 100$
- g. **Calculation:**  $\sqrt{100}, \times 5, + 4, \div 9, \times 7, + 2, \div 4$
- h. **Roman Numerals:** Compare: XXIII ○ 23

Choose an appropriate problem-solving strategy to solve this problem. Fausta wants to use 1-inch cubes to build a cube with edges 2 inches long. How many 1-inch cubes will she need?

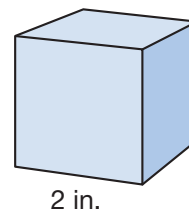

## New Concept

### Math Language

We use cubic units to measure volume because cubes are three-dimensional and volume is a measure of the amount of three-dimensional space inside a figure.

The **volume** of an object is the amount of space the object occupies. Geometric figures that occupy space include cubes, spheres, cones, cylinders, pyramids, and combinations of these shapes. In this lesson we will concentrate on finding the volume of rectangular solids.

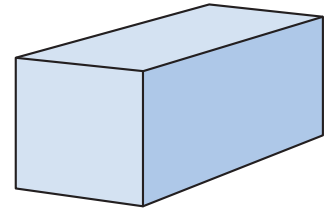

Rectangular solid

The units we use to measure volume are **cubic units**. Here we illustrate the three types of units we use to measure distance, area, and volume.

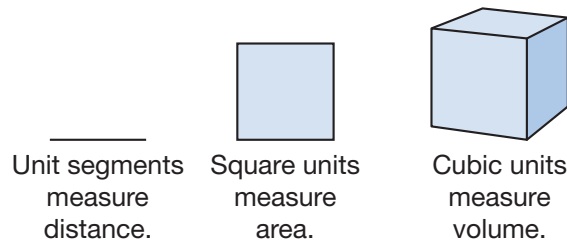

### Example 1

Give an example of a unit that might be used to measure

- the amount of molding around a room.
- the amount of carpet on the floor of a room.
- the maximum storage capacity of a room.

- Molding is a physical example of perimeter, which is a measure of distance. We might use **feet**.
- Carpeting is a physical example of area. We might use **square feet** ( $\text{ft}^2$ ).
- The maximum storage capacity is the volume of the room. We might use **cubic feet** ( $\text{ft}^3$ ).

To find the volume of an object, we calculate the number of cubic units of space the object occupies.

How many 1-inch cubes are needed to build the 2 in. by 2 in. cube?

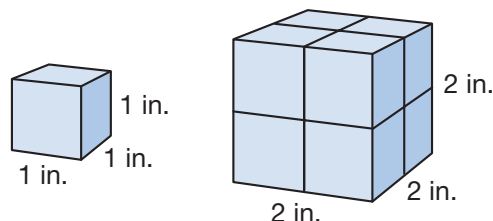

The larger cube is 2 inches long, 2 inches wide, and 2 inches high. We see that the cube is built from eight 1-inch cubes. Each 1-inch cube occupies 1 cubic inch of space. So the volume of the cube is 8 cubic inches.

### Example 2

**Find the volume of this rectangular solid.**

The solid is 3 cm long, 2 cm wide, and 2 cm high. There are 6 cubes in each layer of the solid. The solid has 2 layers, so there are 12 cubes in all. Since the cubes are 1-cm cubes, the volume is **12 cubic centimeters**.

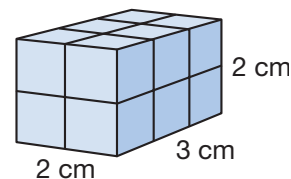

**Justify** Why is the answer labeled cubic centimeters and not square centimeters?

### Example 3

**What is the volume of this solid?**

The solid is 4 inches long, 2 inches wide, and 3 inches high. For the bottom layer, we imagine a 4-by-2 rectangle of 1-inch cubes, which is 8 cubes. Three layers are needed for the whole solid. Since  $3 \times 8 = 24$ , the volume is **24 cubic inches**.

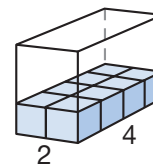
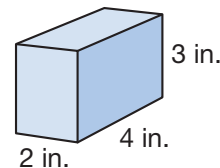

Notice that in Examples 2 and 3, we found the number of cubes on the bottom layer and then multiplied that number by the number of layers, which is the height of the solid. We can find the number of cubes on the bottom layer by multiplying the length and width of the rectangular solid. Then we find the volume by multiplying by the height.

$$\text{Volume} = \text{length} \times \text{width} \times \text{height}$$

$$V = l \times w \times h$$

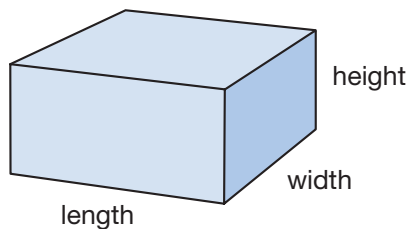

### Example 4

Emma keeps the quilts she makes in a sturdy cardboard box.

- She plans to cover the top of the box with fabric. Choose a formula and use it to decide how much fabric she needs.
- How much space is inside the box? Choose a formula and use it to determine the volume of the box.

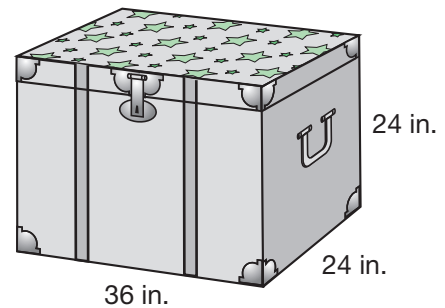

- The top of the box is a rectangle. The fabric covers the area of the rectangle, so we use the area formula.

$$A = l \times w$$

$$A = 36 \text{ in.} \times 24 \text{ in.}$$

$$A = 864 \text{ sq. in.}$$

Emma needs a 36 in. by 24 in. rectangle of fabric, which is **864 square inches**.

- The space inside the box is the volume of the box. We use the volume formula.

$$V = l \times w \times h$$

$$V = 36 \text{ in.} \times 24 \text{ in.} \times 24 \text{ in.}$$

$$V = 20,736 \text{ cu. in.}$$

The volume of the box is **20,736 cubic inches**.

### Example 5

As Dion ate breakfast, he estimated the volume of the cereal box. What is the approximate volume of the box?

We round the length, width, and height to the nearest inch. The base is about 8 inches by 3 inches. The box is about 12 inches tall.

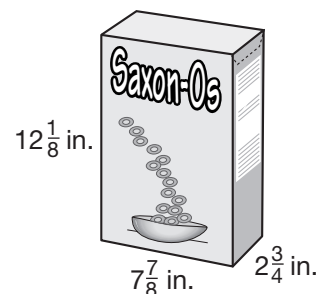

$$V = l \times w \times h$$

$$V = 8 \text{ in.} \times 3 \text{ in.} \times 12 \text{ in.}$$

$$V = 288 \text{ cu. in.}$$

We find that the volume of the cereal box is about **288 cubic inches**.

**Example 6**

Dion wanted to find the total area of the outside of the Saxon-O's cereal box. He decided to cut open the box and he laid it flat. He noticed that the creases divided the figure into 6 rectangles. Each rectangle is one of the panels (faces) of the box. To find the approximate area of the outside surface of the box, he estimated the area of each rectangle and then added the six areas. Find the approximate area of the outside surface of the box.

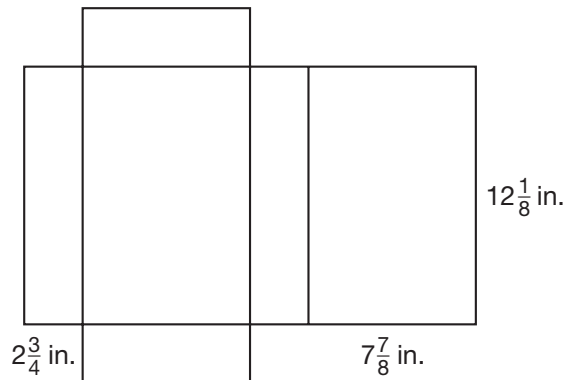

We can estimate the areas of the rectangles by rounding the dimensions to whole numbers. For the given number of inches, we round  $2\frac{3}{4}$  to 3, we round  $7\frac{7}{8}$  to 8, and we round  $12\frac{1}{8}$  to 12. We see that there are three different sizes of rectangles and two of each size. We find the approximate area of each rectangle. Then we add and find that the approximate area of the outside surface of the box is

$$24 + 24 + 36 + 36 + 96 + 96 = \mathbf{312 \text{ sq. in.}}$$

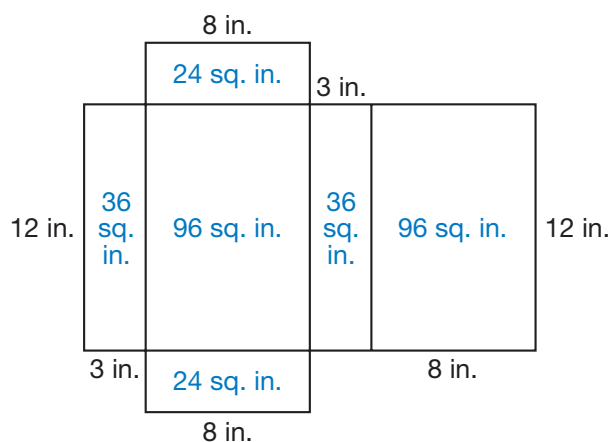



## Lesson Practice

Find the volume of each rectangular solid:

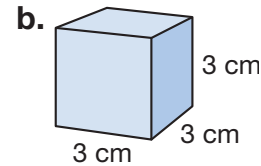
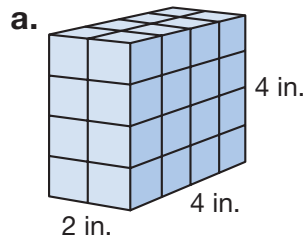

c. Which type of unit will be used to record the volume of a rectangular prism: inches, square inches, or cubic inches?

d. **Multiple Choice** Ella's dad bought her a clear case to display her autographed baseball.

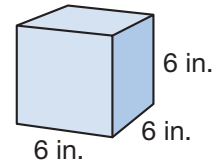

Which formula can be used to find the volume of the case?

**A**  $4s$       **B**  $l \times w$       **C**  $2l + 2w$       **D**  $l \times w \times h$

e. Use a formula to find the volume of the chest that Ella's dad built.

f. In inches, a box of Lamont's favorite wheat crackers measures  $5\frac{1}{4}$  by  $2\frac{1}{8}$  by  $7\frac{5}{8}$ . What is a reasonable estimate in cubic inches of the volume of the box? Explain how you made your estimate.

## Written Practice

*Distributed and Integrated*

- \*1. <sup>(97)</sup> The waiting room had 15 magazines and 25 children's books. What was the ratio of magazines to children's books in the waiting room?
2. <sup>(71)</sup> **Analyze** The weight of a banana's peel is about  $\frac{1}{3}$  of the weight of the banana. If a banana weighs 12 ounces, then the weight of the peel would be about how many ounces? About what percent of the weight of a banana is the weight of the peel?
3. <sup>(57, 80)</sup> **Analyze** What is the probability that a standard number cube, when rolled, will stop with a prime number on top?
4. <sup>(71, 81)</sup> **Connect** Name the total number of shaded circles as a decimal number and as a reduced mixed number.

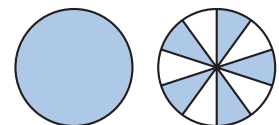

5. Which digit in 1.234 is in the same place as the 6 in 56.78?  
(64)

6. If the radius of a wheel is 30 centimeters, then how many centimeters is its diameter?  
(53)

7. Twenty-seven students enter a classroom and seat themselves in rows of 6. Each row has 6 students except for the last row. How many rows of 6 students will be seated in the classroom? How many students will be seated in the last row?

8.  **Justify** Mr. Alfredson's family loves to read. Last night Mr. Alfredson read a book for 15 more minutes than his son and for 10 fewer minutes than his daughter. Mr. Alfredson read for 30 minutes. Altogether, how many minutes did the family spend reading? Explain why your answer is reasonable.  
(49)

9. **Connect** Which arrow could be pointing to 5.8 on this number line?  
(66)

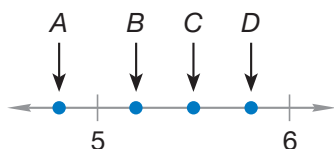

\* 10. Estimate the perimeter and area of this rectangle by first rounding the length and width to the nearest inch.  
(72, 101)

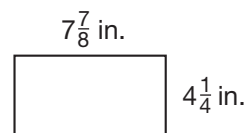

\* 11. Draw a parallelogram that has at least one obtuse angle. How many acute angles does the parallelogram have?  
(31)

\* 12.  $3 - 2.35$   
(102)

\* 13.  $10 - 4.06$   
(102)

14.  $4.35 + 12.6 + 15$   
(99)

15.  $7 \times 47 \times 360$   
(18, 56)

16.  $2^5$   
(78)

17.  $\$47.00 \div 20$   
(54)

18.  $\sqrt{25} - \sqrt{9}$   
(78)

\* 19.  $16x = 2112$   
(26, 92)

20.  $3\frac{2}{3} + 2 - \frac{2}{3}$   
(63)

21.  $\frac{1}{2} \times 4 \times \frac{1}{4}$   
(24, 86)

\*22.  $1 \div \frac{7}{5}$   
(96)

\*23.  $\frac{3}{2} \div \frac{2}{3}$   
(96)

24.  $\frac{4}{10} \times \frac{5}{10}$   
(90)

25.  $\frac{1}{25} = \frac{\square}{100}$   
(79)

26. Reduce:  $\frac{500}{1000}$   
(90)

\*27. a. What is the volume of this rectangular solid?  
(83, 103)

b. How many faces does it have?

c. How many vertices does it have?

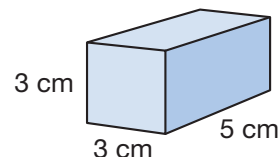

\*28. a. Write the coordinates of each vertex of triangle ABC.  
(Inv. 8)

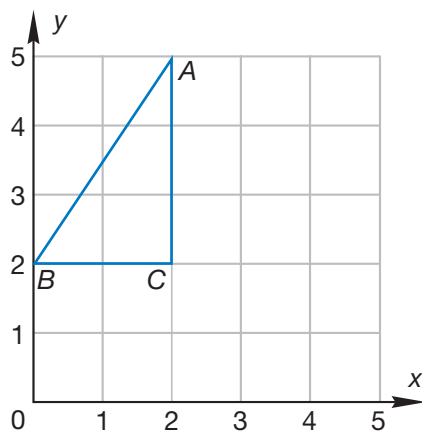

b. Copy the grid and triangle ABC on your paper. Then draw the position of the triangle after a rotation of  $90^\circ$  around point C.

\*29. Use an inch ruler to measure the sides of this triangle. Refer to the illustration and measurements to solve parts a–c.  
(44, 53)

a. How many inches long is each side of the triangle?

b. What is the perimeter of the triangle?

c. Classify the triangle by sides and by angles.



- \*30.** In a presidential election, each state is assigned a number of electoral votes. To become president, a candidate must win 270 or more electoral votes. The graph below shows the numbers of electoral votes assigned to four states by the 2000 Census.

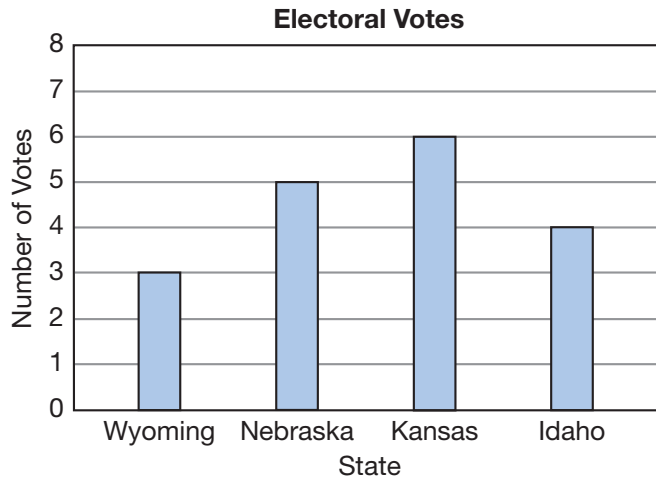

- What number represents the median number of electoral votes of these four states?
- The state of California is assigned eleven times the number of electoral votes as the state of Nebraska is assigned. How many electoral votes are assigned to the state of California?
- Suppose a candidate for president won 12 electoral votes by winning three of the states shown in the graph. Which three states did the candidate win?

**Early Finishers**  
Real-World Connection

- Use a meterstick to measure the length, width, and height of a box in the classroom to the nearest centimeter.
- Then use your measurements to find the volume of the box.
- Convert the volume from centimeters to meters.

• **Rounding Decimal Numbers to the Nearest Whole Number**

**Power Up**

**facts**

Power Up J

**mental math**

- a. **Money:**  $100\text{¢} \div 4$
- b. **Number Sense:** Simplify the improper fractions  $\frac{12}{10}$ ,  $\frac{15}{10}$ , and  $\frac{25}{10}$ .
- c. **Percent:** The \$30 skirt is on sale for 10% off. What is 10% of \$30?
- d. **Geometry:** The four angles of a square each measure  $90^\circ$ . What is the total measure of the four angles?
- e. **Fractional Parts:** What is  $\frac{1}{4}$  of \$80?
- f. **Time:** How many hours is 3 days?
- g. **Calculation:**  $\sqrt{36} + \sqrt{9}$
- h. **Roman Numerals:** Compare 26 ○ XXIV

**problem solving**

Choose an appropriate problem-solving strategy to solve this problem. Use your ruler to draw a square that measures 4 inches by 4 inches. What is the area of the rectangle? Now draw a second rectangle that has different dimensions but the same area as the square. What dimensions did you use for the second figure? Which figure has a greater perimeter?

**New Concept**

In previous problem sets we have answered questions such as the following:

Is \$7.56 closer to \$7 or \$8?

When we answer this question, we are rounding \$7.56 to the nearest dollar. This is an example of rounding a decimal number to the nearest whole number. Using rounded numbers helps us to estimate.

A number written with digits after the decimal point is not a whole number. It is between two whole numbers. We will learn how to find which of the two whole numbers it is nearer. A number line can help us understand this idea.

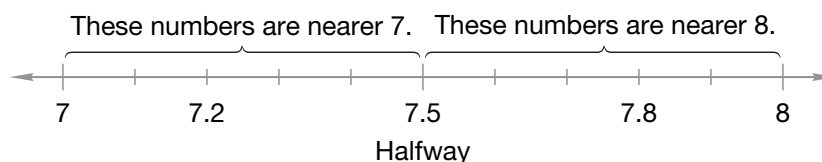

The decimal number 7.5 is halfway between 7 and 8. It is the same distance from 7.5 to 7 as it is from 7.5 to 8. The number 7.2 is less than halfway, so it is nearer 7. The number 7.8 is more than halfway, so it is nearer 8.

Although 7.5 is halfway between 7 and 8, we customarily round up if the digit after the decimal is 5 or more.

### Example 1

**Round 7.6 to the nearest whole number.**

The decimal number 7.6 is greater than 7 but is less than 8. Halfway from 7 to 8 is 7.5. Since 7.6 is more than halfway, we round up to the whole number **8**. We can see on this number line that 7.6 is closer to 8 than it is to 7.

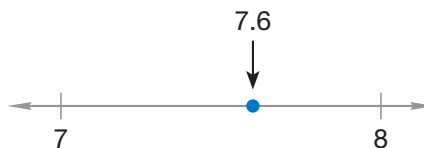

### Example 2

**Estimate the product of 8.78 and 6.12.**

Rounding decimal numbers with two decimal places is similar to rounding money. The decimal number 8.78 rounds to the whole number 9 just as \$8.78 rounds to \$9. Likewise, 6.12 rounds to the whole number 6. We multiply 9 by 6 and find that the product of 8.78 and 6.12 is about **54**.

### Example 3

Vera has a flower and vegetable garden in her backyard. This rectangle represents the dimensions of the garden. What is a reasonable estimate of its area?

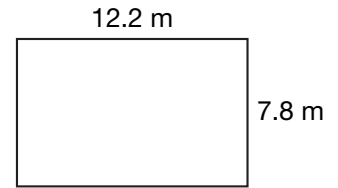

We round the length to 12 m and the width to 8 m. Then we multiply.

$$A = l \times w$$

$$A = 12 \text{ m} \times 8 \text{ m}$$

$$A = \mathbf{96 \text{ sq. m}}$$

**Justify** Why is the answer labeled square meters and not cubic meters?

### Example 4

A stop sign is an example of a regular polygon. All of the sides of a regular polygon have the same measure.



**What is a reasonable estimate of the perimeter of the sign?**

The shape of a stop sign is a regular octagon. To estimate the perimeter, we will round 31.75 cm to 32 cm and then multiply by 8.

$$P = 8s$$

$$P = 8 \times 32 \text{ cm}$$

$$P = 256 \text{ cm}$$

The perimeter of a stop sign is **about 256 cm**.

**Estimate** How could we perform a rougher estimate mentally to verify that our multiplication is reasonable?

### Example 5

The interior dimensions of a personal storage space are shown in the diagram. What is the approximate volume of the storage space in cubic meters?

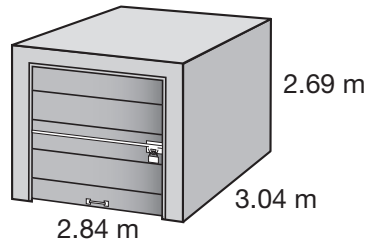

The shape of the space is a rectangular prism. We round each dimension to the nearest whole meter and then calculate the volume.

$$V = l \times w \times h$$

$$V = 3 \text{ m} \times 3 \text{ m} \times 3 \text{ m}$$

$$V = 27 \text{ cu. m}$$

The volume of the storage space is **about 27 cubic meters**.

**Justify** Why is the answer labeled cubic meters and not square meters?

### Lesson Practice

Round each money amount to the nearest dollar:

a. \$6.24

b. \$15.06

c. \$118.59

d. Estimate the sum of \$12.89 and \$6.95.

Round each decimal number to the nearest whole number:

e. 4.75

f. 12.3

g. 96.41

h. 7.4

i. 45.7

j. 89.89

k. Estimate the product of 9.8 and 6.97.

l. **Analyze** Talisha ran one lap in 68.27 seconds. Round her time to the nearest second.

m. The illustration shows the dimensions of a small gift box. Estimate the volume of the box.

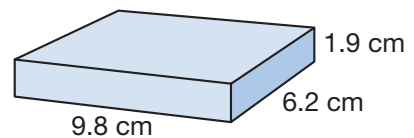



- \* 1. **Represent** <sup>(45)</sup> Draw a quadrilateral with two pairs of parallel sides and no right angles.
- \* 2. **Analyze** <sup>(49, 97)</sup> In Sovann's class there are twice as many boys as there are girls. There are 18 boys in the class.
- How many girls are in the class?
  - How many students are in the class?
  - What is the ratio of boys to girls in the class?
- \* 3. **Analyze** <sup>(84)</sup> Marcia's last seven game scores were 85, 90, 90, 80, 80, 80, and 75.
- Arrange the seven scores in order from lowest to highest.
  - What is the median of the scores?
  - What is the mode of the scores?
- \* 4. **Represent** <sup>(76)</sup> Write this sentence using digits and symbols:  
*The product of one half and one third is one sixth.*
- \* 5. <sup>(68)</sup> Which digit is in the tenths place in 142.75?
- \* 6. <sup>(96)</sup> Compare:  $\frac{1}{2} \div \frac{1}{3} \bigcirc \frac{1}{3} \div \frac{1}{2}$
- \* 7. <sup>(71)</sup> Draw four circles that are the same size. Shade 25% of the first circle, 50% of the second circle, 75% of the third circle, and 100% of the fourth circle. Write a fraction and a decimal to represent the sum of shaded parts.
- \* 8. <sup>(101)</sup> Round  $4\frac{3}{10}$  to the nearest whole number.
- \* 9. <sup>(104)</sup> **a.** Round \$10.49 to the nearest dollar.  
**b.** Round \$9.51 to the nearest dollar.

10. a. The first five multiples of 2 are 2, 4, 6, 8, and 10. What are the first five multiples of 7?  
 (15)
- b. What are the common factors of 2 and 7?

11. **Connect** Which arrow could be pointing to 7.2 on this number line?  
 (12, 66)

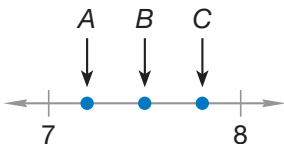

- \* 12. **Estimate** Find the area and perimeter of this rectangle by first rounding the length and width to the nearest centimeter.  
 (72, 104)

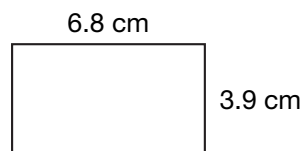

\* 13.  $6.4 + 2.87 + 4$   
 (99)

14.  $(\$16 - \$5.74) \div 6$   
 (13, 24)

15.  $\$5.64 \times 10$   
 (29)

16.  $976 \times 267$   
 (55)

- \* 17. **Analyze** All these ratios are equal. What is the quotient of each division? Explain how you found your answer.  
 (97)

$$\frac{640}{32}, \frac{320}{16}, \frac{160}{8}, \frac{80}{4}$$

18. Write a fraction equal to  $\frac{2}{3}$  with a denominator of 9. Then add  $\frac{7}{9}$  to the fraction you wrote. Remember to convert the sum to a mixed number.  
 (75, 79)

19.  $5\frac{2}{5} + a3 - \frac{1}{3}b$   
 (63, 75)

20.  $2 \times a\frac{1}{2} \times \frac{1}{3}b$   
 (76, 86)

21.  $\frac{3}{10}$  of 30  
 (86)

22.  $\frac{4}{25} = \frac{\square}{100}$   
 (79)

- \* 23. **Conclude** Determine a possible pattern for this sequence, and draw the next figure.  
 (Inv. 4)

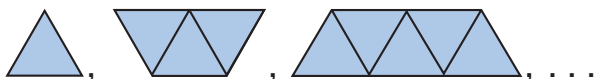

- 24.** (Inv. 8) Locating a town on a map grid is similar to locating a point on a coordinate plane. However, a map is divided into horizontal and vertical bands, and one axis is often lettered rather than numbered. Use the map to answer parts **a–c**.

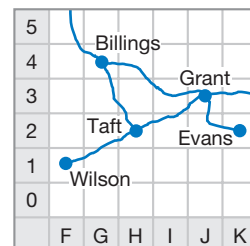

- a. Multiple Choice** We find Taft in region H2. In which region do we find Billings?
- A** G4      **B** F4      **C** H2      **D** F5
- b.** What town do we find in region J3?
- c.** What letter and number show where to find Evans?

**25.** (78)  $10^2 - \sqrt{100}$

- \*26. a.** Write the coordinates of each vertex of triangle *ABC*. (Inv. 8)

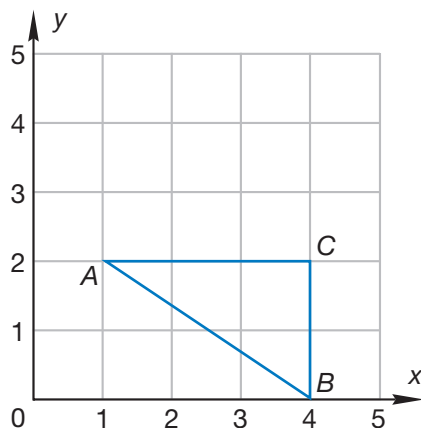

- b.** Copy the grid and triangle. Then draw the triangle as it would appear after a reflection across side *AC*.

- \*27. a.** What is the volume of a box with the dimensions shown? (83, 103)

- b.** How many vertices does the box have?

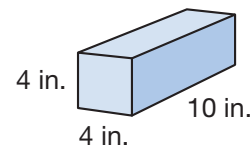

- \*28.** (71, 91) In 2000, about 28% of the people living in Texas were under age 18. Write 28% as a reduced fraction.

- \*29. Multiple Choice** Three friends ride the school bus each day. Mariano rides for 5 fewer minutes than Lon, and Lon rides for 3 more minutes than Carson. Mariano rides for 4 minutes. Which expression can be used to find the length of time Carson rides the bus?
- (49)
- A**  $4 + 5 - 3$       **B**  $3 - (5 - 4)$       **C**  $5 + 3 - 4$       **D**  $4 + 3 + 5$

- 30. Multiple Choice** Two thirds of the 18 students in a study hall worked to complete their homework. The other students in the study hall read a book. Which diagram shows the number of students who read a book?
- (46)

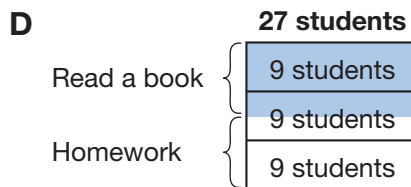
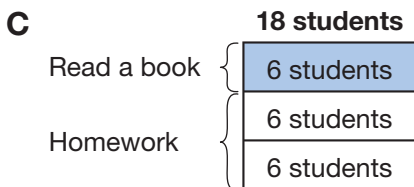
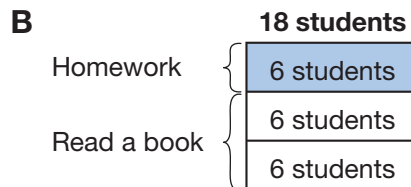
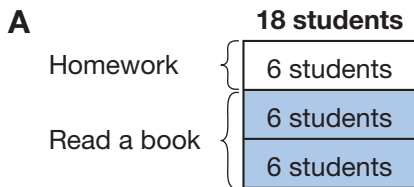

## Early Finishers

Real-World Connection

Mr. Rollins is building a rectangular run for his dog. The run is 6.25 meters long and 4.5 meters wide.

- Estimate the area of the dog run.
- How many meters of fencing material will he need to build a fence around the dog run?
- If the fencing is sold in sections that are 2 meters long, then how many sections will Mr. Rollins need to buy?

## • Symmetry and Transformations

### Power Up

#### facts

#### Power Up J

#### mental math

- a. **Estimation:** Estimate the cost of 8 yards of fabric if the price of the fabric is \$6.95 per yard.
- b. **Estimation:** MarVel's dog weighs 18.2 kg, and his cat weighs 4.9 kg. Round each weight to the nearest kilogram and then add to estimate the total weight of MarVel's pets.
- c. **Fractional Parts:**  $\frac{1}{5}$  of \$20
- d. **Fractional Parts:**  $\frac{2}{5}$  of \$20
- e. **Fractional Parts:**  $\frac{4}{5}$  of \$20
- f. **Measurement:** The temperature of the cold glass of water is  $2^{\circ}\text{C}$ . The temperature of the hot soup is  $53^{\circ}\text{C}$ . What is the temperature difference between the two liquids?
- g. **Calculation:**  $\sqrt{49}, \times 8, - 1, \div 5, - 1, \times 4, + 2, \div 6$
- h. **Roman Numerals:** Compare: XXXVI  $\bigcirc$  34

#### problem solving

Choose an appropriate problem-solving strategy to solve this problem. Alex erased the product and one of the factors in a multiplication problem and gave it to Taylor as a problem-solving exercise. He told Taylor that the digits of the product are 1, 2, and 7, though not in that order. Copy Alex's multiplication problem and find the missing digits for Taylor.

$$\begin{array}{r} \text{---} \\ \times \quad \text{---} \\ \hline \text{---} \end{array} 4$$

## New Concept

### symmetry

#### Thinking Skill

##### Model

Fold a piece of paper and cut a design on the fold. Predict what the figure will look like when you open the paper.

In this lesson we will look for **lines of symmetry**. Figures that can be divided into *mirror images* by at least one line of symmetry are said to have **reflective symmetry**. If a mirror is placed upright along a line of symmetry, the reflection in the mirror appears to complete the figure.

#### Example 1



Visit [www.SaxonMath.com/Int5Activities](http://www.SaxonMath.com/Int5Activities) for an online activity.

Here we show a regular triangle and a regular pentagon. Find the number of lines of symmetry in each figure.

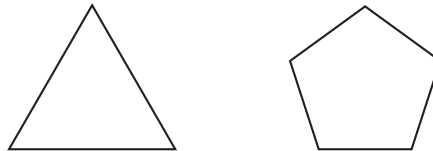

A line of symmetry divides a figure into mirror images. In each of these figures, a line of symmetry passes through a vertex and splits the opposite side into two segments of equal length.

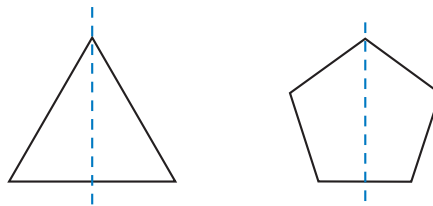

Since these polygons are regular, we find a line of symmetry through each vertex of the polygon.

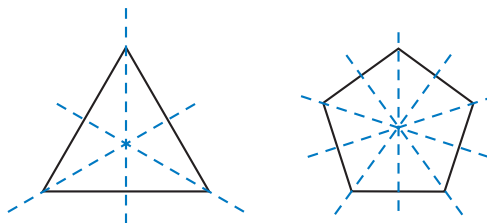

So the regular triangle has **three** lines of symmetry, and the regular pentagon has **five** lines of symmetry.

#### Thinking Skill

##### Conclude

How many lines of symmetry does an isosceles triangle have?

## Example 2

Here we show a regular quadrilateral and a regular hexagon. Find the number of lines of symmetry in each figure.

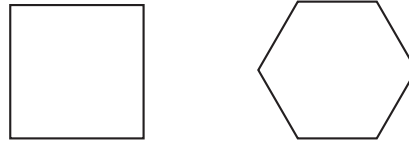

There is a line of symmetry that passes through a vertex and its opposite vertex.

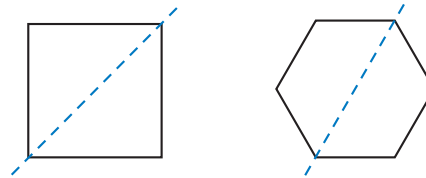

We find two of these lines of symmetry for the square and three for the hexagon.

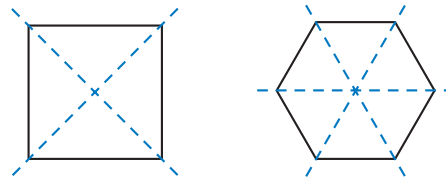

In addition to the lines of symmetry through the vertices, there are lines of symmetry through the sides of these figures.

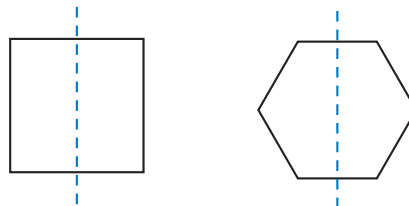

Again we find two such lines of symmetry for the square and three for the hexagon.

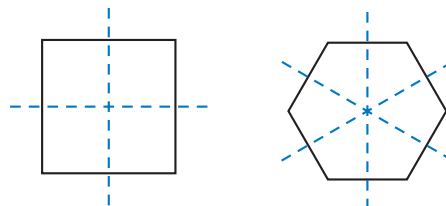

In all we find **four** lines of symmetry for the square and **six** lines of symmetry for the hexagon.

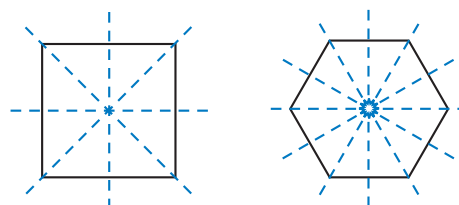

Besides having reflective symmetry, regular polygons also have **rotational symmetry**. A figure has rotational symmetry if it regains its original orientation more than once during a full turn. For example, if we rotate an equilateral triangle one third of a turn, the triangle reappears in its original orientation.

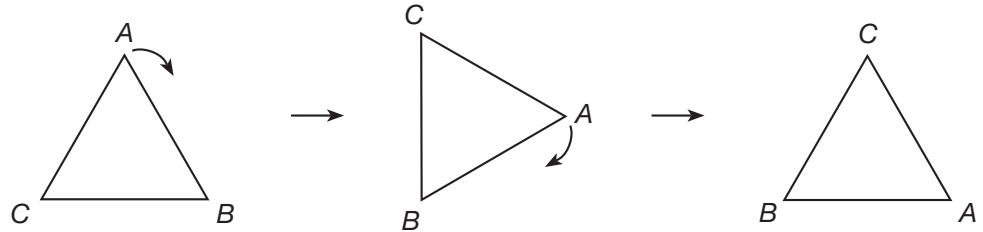

### Example 3

Which of these letters has rotational symmetry?

**M A T H**

If you turn your book as you look at the letters, you will see **H** reappear in its proper orientation after half a turn. It is the only letter of these four with rotational symmetry.

### Example 4

On the grid, there is an L-shaped figure and its reflection. Is there a line of symmetry between the figure and its image?

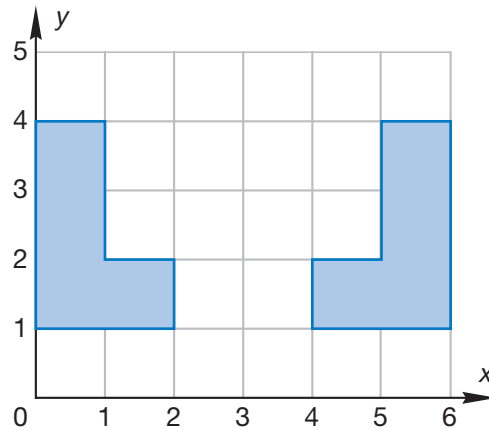

Halfway between the figure and its reflection is the line of symmetry. In this case, **there is a line of symmetry**. It is vertical line  $x = 3$ . The line of symmetry is the line of reflection. The figure on the right is the image of the figure on the left reflected across the line  $x = 3$ .



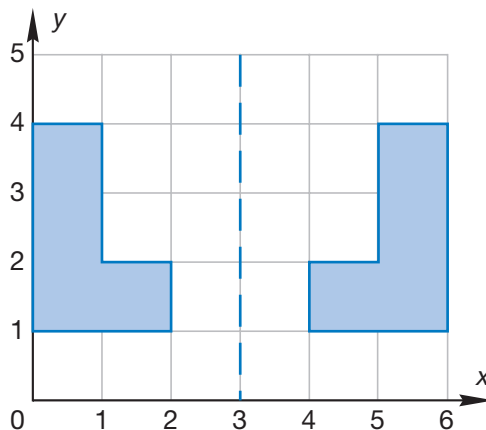

**Conclude** Do all reflections have a line of symmetry? Use sketches to support your answer.

### Example 5

On the grid, an L-shaped figure is translated 4 units to the right. Is there a line of symmetry between the figure and its translated image?

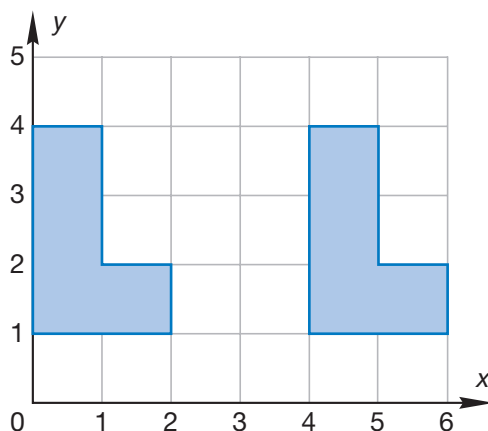

No, there is **not a line of symmetry** between the figure and its image.

**Conclude** Do any translations have a line of symmetry? Explain. Use sketches to support your answer.

### Example 6

On the grid, an L-shaped figure is rotated  $180^\circ$   $Q_2^1$  turn<sub>R</sub> around point A. The original figure and its image are combined to form one new shape. Does the new shape have rotational symmetry?

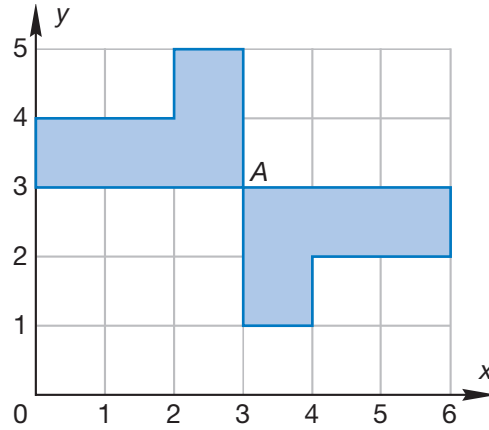

Yes, **the new shape has rotational symmetry**. If we turn our books  $180^\circ$ , we see the same figure appear. However, if the figure were rotated any other number of degrees greater than  $0^\circ$  and less than  $360^\circ$ , then the figure and its image would not have rotational symmetry.

**Conclude** Do all rotations of  $180^\circ$  result in a pair of figures with rotational symmetry? Use sketches to support your answer.

## Lesson Practice

**Represent** Draw each figure and all its lines of symmetry:

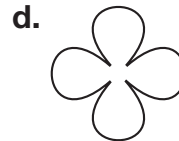
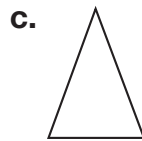

e. A regular octagon has how many lines of symmetry?

f. **Analyze** Which of these letters has rotational symmetry?

# PLUS

g. Copy this grid and figure on your paper. Then draw the image of the figure reflected across the horizontal line  $y = 3$ .

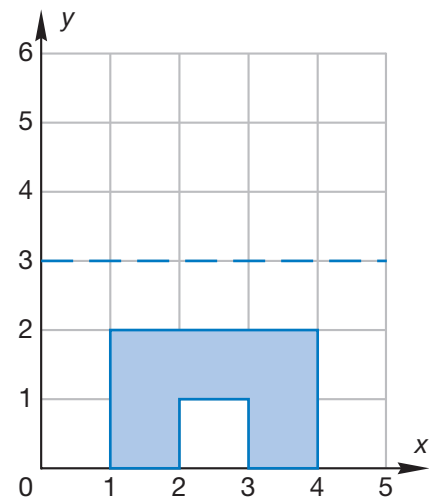

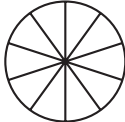
- \*1. <sup>(97)</sup> The ratio of boys to girls in the auditorium was 4 to 5. If there were 40 boys in the auditorium, how many girls were there? (*Hint:* In this problem, the ratio 4 to 5 means that for every 4 boys there were 5 girls.)
2. <sup>(30)</sup> This circle is divided into tenths. How many tenths does it take to equal one whole?
- 
3. <sup>(70)</sup> **Analyze** Dillon had six coins in his pockets totaling 43¢. How many of the coins were nickels?
4. <sup>(68)</sup> **Represent** Faith finished the race in ten and twenty-three hundredths seconds. Use digits to write that number of seconds.
5. <sup>(49)</sup> If 20 comic books cost \$50, how many comic books could you buy with \$100? Explain how you found your answer.
- \*6. <sup>(79, 90)</sup> **Analyze** Write a fraction equal to  $\frac{1}{2}$  that has a denominator of 10. Then subtract that fraction from  $\frac{9}{10}$ . Remember to reduce the answer.
7. <sup>(50)</sup> **Analyze** Blanco and Felicia had three days to read a book. Blanco read 40 pages the first day, 60 pages the second day, and 125 pages the third day. Felicia read the same book, but she read an equal number of pages each of the three days. How many pages did Felicia read each day?
8. <sup>(62)</sup> Estimate the cost of 12 notebooks priced at \$1.95 each.
- \*9. <sup>(104)</sup> Estimate the quotient when 20.8 is divided by 6.87 by rounding both decimal numbers to the nearest whole number before dividing.
- \*10. <sup>(102)</sup> In a 100-meter dash, Gregory ran fourteen hundredths of a second faster than an opponent who ran the race in 13.02 seconds. How long did it take Gregory to run the race?

- \* 11.** **a.** Name the coordinates of each vertex of rectangle  $ABCD$ .  
(72, Inv. 8)
- b.** The area of rectangle  $ABCD$  is how many square units?
- c.** The perimeter of the rectangle is how many units?

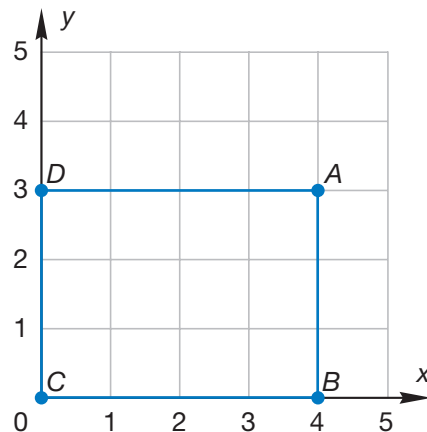

- \* 12.** The rectangle in problem 11 has how many lines of symmetry?  
(105)

- 13.** Refer to quadrilateral  $ABCD$  to answer parts **a–c**.  
(45, 61)

- a.** Recall that a right angle is sometimes marked with a square in the corner. Both  $\angle CDA$  and  $\angle DCB$  are right angles. Which angle appears to be acute?
- b.** Which two sides are parallel?
- c.** What type of quadrilateral is quadrilateral  $ABCD$ ?

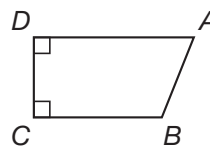

**14.**  $\frac{1}{100} + \frac{9}{100}$   
(90)

**15.**  $\frac{63}{100} - \frac{13}{100}$   
(90)

**16.**  $\frac{5}{10} \times \frac{5}{10}$   
(90)

**\* 17.**  $\frac{3}{5} \div \frac{3}{4}$   
(96)

**\* 18.**  $3.76 + 12 + 6.8$   
(99)

**\* 19.**  $12 - 1.25$   
(102)

**20.**  $\sqrt{64} + \sqrt{36}$   
(78)

**21.**  $31^2$   
(78)

**22.**  $28 \overline{)5964}$   
(94)

**23.**  $14m = 5964$   
(26, 94)

**24.**  $\frac{3}{20} \times \square = \frac{15}{100}$   
(79)

**25.**  $\frac{7}{25} = \frac{\square}{100}$   
(79)

- \* 26.** Draw a regular quadrilateral and show its lines of symmetry.  
(45, 105)

\*27. a. What is the volume of a box of cereal with these dimensions?  
(83, 103)

b. How many edges does the box have?

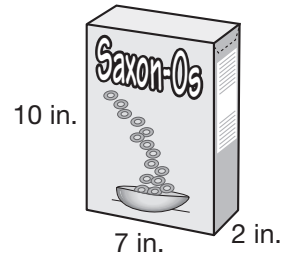

28. **Interpret** The line graph shows temperatures at different times on an April afternoon in Mexico City, Mexico. Use the graph to answer the questions that follow.  
(Inv. 6)

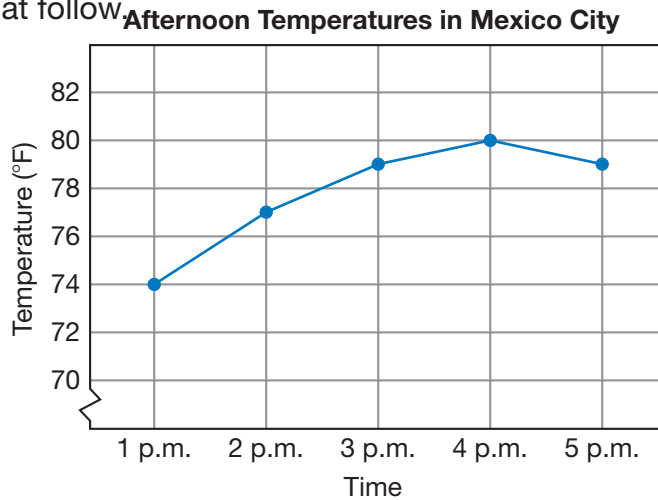

- At which two times of the day were the temperatures the same?
- During which one-hour period of time did the greatest temperature decrease occur? What was that decrease?
- The low temperature that day in Mexico City was  $26^\circ$  lower than the 4 p.m. temperature. What was the low temperature that day?

\*29. a. Which of these letters has rotational symmetry?  
(105)

T E N

b. Which letters have reflective symmetry?

30. **Estimate** In the 2000 presidential election, the number of votes cast in Dickenson County, Virginia, is shown in the table.  
(62)

What is a reasonable estimate of the total number of votes cast for the two candidates? Explain your answer.

**2000 Election Results  
Dickenson County, Virginia**

Candidate	Number of Votes
Bush (R)	3,122
Gore (D)	3,951

• **Reading and Ordering  
Decimal Numbers Through  
Ten-Thousandths**

**Power Up**

**facts**

Power Up J

**mental math**

- a. **Measurement:** One milliliter of water has a mass of 1 gram. What is the mass of 1 liter of water?
- b. **Measurement:** How many pounds is two and a half tons?
- c. **Fractional Parts:**  $\frac{1}{3}$  of 100
- d. **Fractional Parts:**  $\frac{2}{3}$  of 100
- e. **Time:** D’Nietra’s science class begins at 1:20 p.m. It ends 50 minutes later. At what time does her science class end?
- f. **Powers/Roots:**  $2^3 + 3^2$
- g. **Calculation:**  $20 \times 30, + 40, \div 10$
- h. **Roman Numerals:**<sup>1</sup> Write CCX in our number system.

**problem  
solving**

Choose an appropriate problem-solving strategy to solve this problem. A roll of nickels contains 40 nickels. A roll of dimes contains 50 dimes. A roll of quarters contains 40 quarters. Using at least one roll of each of these coins, find a combination of these rolls that totals \$25.

**New Concept**

As we move to the right on the following chart, we see that each place is one tenth of the value of the place to its left.

<sup>1</sup> In Lessons 106–120 the Mental Math section “Roman numerals” reviews concepts from Appendix Topic B. You may skip these Mental Math problems if you have not covered Appendix Topic B.

### Reading Math

The ones place is the center of the place-value chart. The value of each place to the left of the ones place is multiplied by 10. The value of each place to the right of the ones place is divided by 10.

hundreds place	tens place	ones place	tenths place	hundredths place	thousandths place	ten-thousandths place
100.	10.	1.	0.1	0.01	0.001	0.0001
$10 \times 10$	$10 \times 1$	1	$1 \div 10$	$1 \div 100$	$1 \div 1000$	$1 \div 10,000$
			$\frac{1}{10}$	$\frac{1}{100}$	$\frac{1}{1000}$	$\frac{1}{10,000}$

To name decimal numbers with three decimal places, we use the word *thousandths*. To name numbers with four decimal places, we use *ten-thousandths*.

### Example 1

Use words to name 12.625.

It is **twelve and six hundred twenty-five thousandths**.

### Example 2

Round 7.345 to the nearest whole number.

The number 7.345 is a number that is 7 plus a fraction, so it is more than 7 but less than 8. We need to decide whether it is nearer 7 or nearer 8.

Remember that zeros at the end of a decimal number do not change the value of the number. The halfway point between 7 and 8 may be named using any number of decimal places.

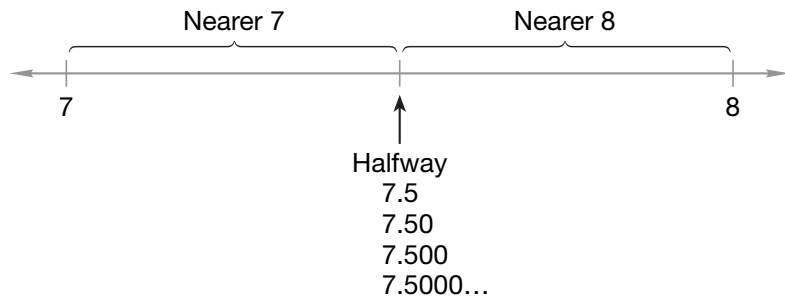

Since 7.500 is halfway between 7 and 8, the number we are rounding, 7.345, is less than halfway.

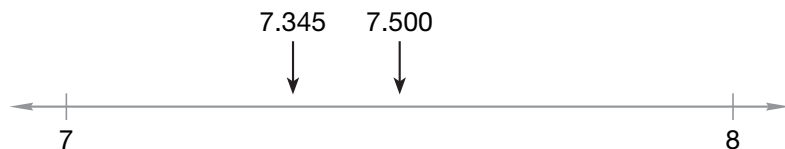

This means 7.345 rounds down to the whole number **7**.

**Example 3**

**Compare: 4.5 ○ 4.456**

The comparison is easier to see if the numbers have the same number of decimal places. We will attach zeros to 4.5 so that it has the same number of decimal places as 4.456. We see that 4.5 is greater.

$$4.500 > 4.456$$

**Example 4**

**Arrange these decimal numbers in order from least to greatest:**

**0.45, 0.457, 0.5**

The size of a decimal number is determined by place value, not by the number of digits. One way to focus attention on place value is to list the numbers with decimal points aligned.

0.45

0.457

0.5

The digits in the ones place are all zeros, so we look at the tenths place. We see that 0.5 is greatest. Both 0.45 and 0.457 have 4 in the tenths place and 5 in the hundredths place. However, 0.45 has zero in the thousandths place, so it is less than 0.457.

**0.45, 0.457, 0.5**

**Example 5**

**Write 0.457 as a fraction. Then name both numbers.**

A decimal number with three decimal places can be written as a fraction with a denominator of 1000.

$$0.457 = \frac{457}{1000}$$

Both numbers are named **four hundred fifty-seven thousandths**.



## Lesson Practice

- a. Write the amount as a decimal number using words and in word, decimal, and fraction form.



**Represent** Use words to name each number:

- b. 6.875                      c. 0.025                      d. 0.16

Round each decimal number to the nearest whole number:

- e. 4.375                      f. 2.625                      g. 1.33

- h. Compare:  $0.375$   $\bigcirc$   $0.0375$

- i. Arrange these numbers in order from least to greatest:

0.15, 0.102, 0.125, 0.1

- j. **Represent** Use digits to write one hundred twenty-five thousandths.

## Written Practice

*Distributed and Integrated*

1. **Analyze** Jayden was given a \$100 gift certificate. If he could buy <sup>(49)</sup> 6 books with \$25, how many books could he buy with his \$100 gift certificate?
  
- \*2. <sup>(102)</sup> A meter is 100 centimeters, so a centimeter is one hundredth of a meter (0.01 meter). A meter was divided into two parts. One part was 0.37 meter long. How long was the other part?
  
3. <sup>(71, 90)</sup> Name the total shaded portion of these two squares as a decimal number and as a reduced mixed number.

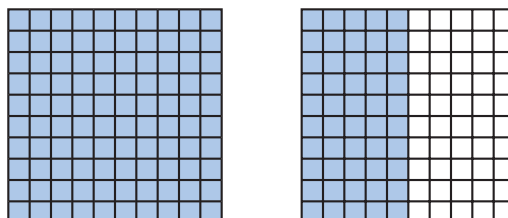

**\*4.** **Estimate** Write the product of 8.33 and 7.667 by rounding both decimal numbers to the nearest whole number before multiplying.  
(106)

**5.** What are the first five multiples of 8?  
(15)

**\*6.** Three fifths of the 30 students in the class were girls.  
(46, 97)

- How many girls were in the class?
- How many boys were in the class?
- What was the ratio of boys to girls in the class?

**7.** **Estimate** Diana and her mom purchased three items at a hardware store. The costs of the items were \$8.95, \$12.29, and \$4.88. Estimate the total cost of the items by first rounding each cost to the nearest dollar.  
(62)

**\*8.** Write 5.375 with words.  
(106)

**\*9. a.** The perimeter of the square below is how many units?  
(72, Inv. 8)

**b.** The area of the square is how many square units?

**c.** Copy the grid and the square. Then draw the image of the square translated one unit to the right and one unit up.

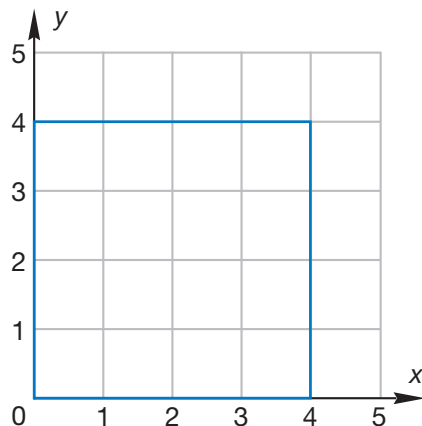

**\*10.** Arrange these numbers in order from least to greatest:  
(106)

0.96, 0.875, 0.9, 1

$$\begin{array}{r} 11. \quad 4\frac{3}{8} \\ (81) \quad + 1\frac{3}{8} \\ \hline \end{array}$$

$$\begin{array}{r} 12. \quad 3\frac{7}{10} \\ (81) \quad + \frac{3}{10} \\ \hline \end{array}$$

$$\begin{array}{r} 13. \quad 4 \\ (63) \quad - 1\frac{3}{10} \\ \hline \end{array}$$

14.  $1.23 + 0.4567 + 0.5$   
(73)

\* 15.  $4 - 1.3$   
(99)

16.  $8 \times 57 \times 250$   
(18, 55)

17.  $5 \times \$7.25$   
(17)

18.  $8 \overline{) \$26.00}$   
(26)

19.  $436 \div 21$   
(94)

20.  $16 \overline{) 5040}$   
(94)

21.  $5 \times \frac{3}{10}$   
(86, 91)

22.  $5 \div \frac{2}{3}$   
(96)

23. Write fractions equal to  $\frac{1}{6}$  and  $\frac{1}{8}$  that have denominators of 24. Then add the fractions.  
(79)

\* 24. The graph at right shows the fraction of students in a class who have shoes of a certain color. Use the graph to answer parts **a** and **b**.  
(71)

Shoe Color of Students

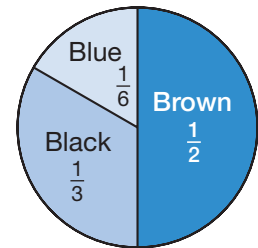

a. There are 30 students in the class. How many students have black shoes? What percent of the students have black shoes?

b. **Multiple Choice** Which two groups, taken together, total one half of the class?

- A** black and brown                      **B** brown and blue  
**C** blue and black                        **D** blue and red

\* 25. a. What is the volume of a cube with the measurements shown?  
(83, 103)

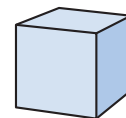

4 in.

b. What is the shape of each surface of the cube?

\* 26. Print the eighth letter of the alphabet in uppercase, and show its lines of symmetry.  
(105)

**\* 27. Analyze** For exercise Claire walked around the park. She walked around the park 4 times Monday, 6 times Tuesday, and 7 times Wednesday. Claire walked around the park an average of how many times each day? Write your answer as a mixed number.

**28. Multiple Choice** Mary spent most of one day hiking up Giant Mountain in Adirondack Park in New York. During the hike she drank about three pints of water. About how many ounces of water did Mary drink?

- A** 32 oz      **B** 48 oz      **C** 64 oz      **D** 100 oz

**29.** One fifth of the art projects displayed on a bulletin board are charcoal sketches. Two fifths of the projects are watercolor drawings. What fraction of the projects are charcoal sketches or watercolor drawings?

**30. Multiple Choice** On Friday morning, three fourths of the 24 students in a class wore a jacket to school. Which diagram shows the number of students who wore a jacket to school?

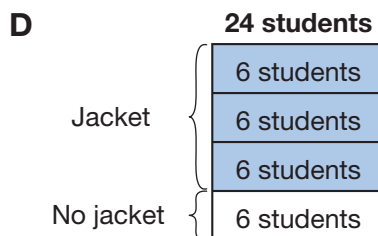
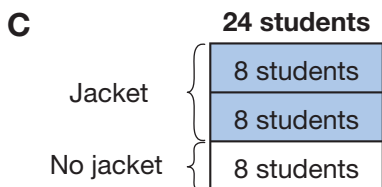
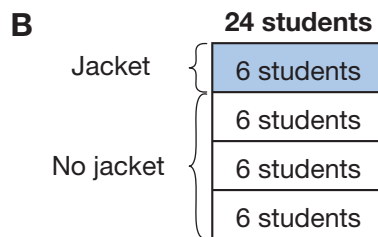
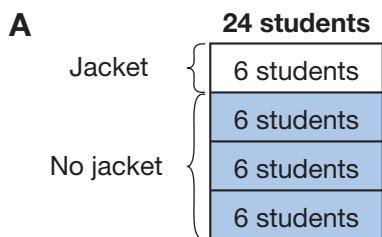

**Early Finishers**

Real-World Connection

Neil's class compared the maximum spans of several different bridges in the United States to learn about length. They found that the Golden Gate Bridge spans 0.795 mile, the Brooklyn Bridge spans 0.302 mile, the Mackinac Straights Bridge spans 0.72 mile, and the Verrazano-Narrows Bridge spans 0.802 mile.

- Use these lengths to list these bridges in order from least to greatest.
- Write each decimal number as a fraction.

## • Using Percent to Name Part of a Group

### Power Up

#### facts

Power Up J

#### mental math

- Estimation:** Use compatible numbers to estimate the cost of 9.8 gallons of gas at  $\$2.49\frac{9}{10}$  per gallon.
- Estimation:** Choose the more reasonable estimate for the weight of a sheet of  $8\frac{1}{2}$ -by-11 inch notebook paper: 2 g or 2 kg.
- Percent:** What is 50% of \$40? ... 25% of \$40? ... 10% of \$40?
- Measurement:** Sierra needs one quart of water to mix with the frozen juice concentrate. How many times must she fill a pint container to measure out one quart?
- Measurement:** Antonia needs a gallon of water to mix with detergent. How many times must she fill a quart container to measure out one gallon?
- Geometry:** Two angles of the parallelogram each measure  $75^\circ$ . The other two angles each measure  $105^\circ$ . What is the total measure of the four angles?
- Calculation:**  $\sqrt{49} \times \sqrt{49}$
- Roman Numerals:** Write LXV in our number system.

#### problem solving

Choose an appropriate problem-solving strategy to solve this problem. If a coin is flipped, there are two possible outcomes: heads (H) or tails (T). If a coin is flipped twice, there are four possible outcomes: heads then heads (H, H), heads then tails (H, T), tails then heads (T, H), or tails then tails (T, T). How many outcomes are possible for a coin that is flipped three times? List all the possible outcomes, starting with heads then heads then heads (H, H, H).

## New Concept

### Reading Math

A denominator of 100 is used to write a percent as a fraction.

$$1\% = \frac{1}{100}$$

$$50\% = \frac{50}{100}$$

$$100\% = \frac{100}{100}$$

$$125\% = \frac{125}{100}$$

*Percent* is a word that means “out of 100.” If we read that 50 percent of all Americans drive cars, we understand that 50 out of every 100 Americans drive cars. Likewise, the statement “Ten percent of the population is left-handed” means that 10 out of every 100 people are left-handed. When we say “percent,” we speak as though there were 100 in the group. However, we may say “percent” even when there are more than or less than 100 in the group.

Like fractions, percents name parts of a whole. We have used fraction manipulatives to learn the percents that are equivalent to some fractions. In this lesson we will learn how to find percents for other fractions by renaming the fraction with a denominator of 100.

### Example 1

#### Thinking Skill

##### Verify

What property of multiplication states that we can multiply any number by 1 and not change the value of the number?

**If 8 of the 20 students are boys, what percent of the students are boys?**

If we write the number of boys over the total number of students in the group, we get 8 boys over 20 total. If we multiply this fraction by a name for 1 so that the denominator becomes 100, the numerator will be the percent. We multiply by  $\frac{5}{5}$ .

$$\frac{8 \text{ boys}}{20 \text{ total}} \times \frac{5}{5} = \frac{40 \text{ boys}}{100 \text{ total}}$$

This means that if there were 100 students, there would be 40 boys. Thus, **40 percent** of the students are boys.

### Example 2

**There were 400 beads in all. If 60 beads were red, what percent of the beads were red?**

We have the fraction 60 beads over 400 total. We can partially reduce this fraction ratio to make the denominator equal 100. We do this by dividing each term by 4.

$$\frac{60 \text{ red beads} \div 4}{400 \text{ total} \div 4} = \frac{15 \text{ red beads}}{100 \text{ total}}$$

When the denominator is 100, the top number is the percent. Thus, **15 percent** of the beads were red.

Instead of using the word *percent*, we may use the percent sign (%). Using the percent sign, we write 15 percent as **15%**.

Some fractions are not easily renamed as parts of 100. Let's suppose that  $\frac{1}{6}$  of the students rode a bus to school. What percent of the students rode a bus to school?

$$\frac{1}{6} = \frac{?}{100}$$

**Thinking Skill**

**Connect**

What are the factors of 100?

Since 100 is not a multiple of 6, there is no whole number by which we can multiply the numerator and denominator of  $\frac{1}{6}$  to rename it with a denominator of 100. However, we can find  $\frac{1}{6}$  of 100% by multiplying and then dividing.

$$\begin{aligned} \frac{1}{6} \times 100\% &= \frac{100\%}{6} \\ &= 16\frac{4}{6}\% = 16\frac{2}{3}\% \\ &\rightarrow 6 \overline{) 100\%} \\ &\quad \underline{6} \\ &\quad 40 \\ &\quad \underline{36} \\ &\quad \quad 4 \end{aligned}$$

We find that  $\frac{1}{6}$  equals  $16\frac{2}{3}\%$ .

**Connect**

Explain how to write a quotient and a remainder as a mixed number.

**Example 3**

The team won  $\frac{2}{3}$  of its games. Find the percent of games the team won.

We first multiply  $\frac{2}{3}$  by 100%.

$$\frac{2}{3} \times 100\% = \frac{200\%}{3}$$

Then we divide 200% by 3 and write the quotient as a mixed number.

$$\begin{aligned} &66\frac{2}{3}\% \\ &3 \overline{) 200\%} \\ &\quad \underline{18} \\ &\quad \quad 20 \\ &\quad \quad \underline{18} \\ &\quad \quad \quad 2 \end{aligned}$$

The team won  $66\frac{2}{3}\%$  of its games.

**Lesson Practice**

- If 120 of the 200 students are girls, then what percent of the students are girls?
- If 10 of the 50 apples are green, then what percent of the apples are green?

- c. Sixty out of 300 is equivalent to how many out of 100?
- d. Forty-eight out of 200 is what percent?
- e. Thirty out of 50 is what percent?
- f. If half of the people ate lunch, then what percent of the people ate lunch?
- g. Five minutes is  $\frac{1}{12}$  of an hour. Five minutes is what percent of an hour?

## Written Practice

*Distributed and Integrated*

- \*1. **Analyze** <sup>(99)</sup> La'Retta swam 100 meters in 63.8 seconds. Kathy swam 100 meters 1 second faster than La'Retta. How long did it take Kathy to swim 100 meters?
- \*2. **Estimate** <sup>(72, 101)</sup> Find the approximate area of this rectangle by rounding each dimension to the nearest whole number.
- $9\frac{7}{8}$  in.



$6\frac{3}{4}$  in.
- \*3. **Explain** <sup>(21, 22)</sup>  The camel could carry 245 kilograms. If each bundle of straw weighed 15 kilograms, how many full bundles of straw could the camel carry? Explain how you know your answer is correct.
- \*4. **Estimate** <sup>(104)</sup> Find the total cost of 8 books priced at \$6.98 each by rounding the cost per book to the nearest dollar before multiplying.
- \*5. <sup>(107)</sup> If 60 of the 200 students are girls, then what percent of the students are girls?
- \*6. <sup>(71)</sup> Compare:  $\frac{1}{10} + \frac{1}{10} \bigcirc 0.1 + 0.1$
- \*7. <sup>(101)</sup> Estimate the quotient when 19.8 is divided by 3.875.
- \*8. <sup>(107)</sup> If a bag contains 50 marbles and 10 of them are green, then what percent of the marbles are green?



9. **Analyze** Write a fraction equal to  $\frac{1}{3}$  that has the same denominator as the fraction  $\frac{1}{6}$ . Then add the fraction to  $\frac{1}{6}$ . Remember to reduce your final answer.

10. a. The perimeter of the blue rectangle is how many units?  
b. The area of the blue rectangle is how many square units?

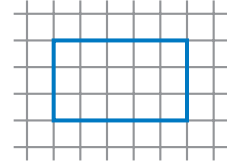

11.  $QT$  equals 9 centimeters.  $QR$  equals  $RS$  equals  $ST$ . Find  $QR$ .

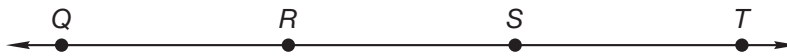

12.  $\frac{31}{100} + \frac{29}{100}$
13.  $5 - 3\frac{7}{10}$
- \* 14.  $5 - 3.7$
15.  $10 \times \$3.65$
16.  $468 \times 579$
17.  $\$36.50 \div 10$
18.  $5 \overline{)8765}$
19.  $640 \div 32$
20.  $\frac{3}{10} \times \frac{7}{10}$
21.  $4 \div \frac{3}{5}$
- \* 22. The table below shows how many votes each candidate received in the class election. Use the table to answer parts a–c.



**Election Results**

Julian	
Debbie	
Patrick	
Chloe	

- a. How many votes did Julian receive?
- b. What fraction of the votes did Chloe receive?
- c. A student in the class noticed that there could have been a four-way tie in the election. If there had been a four-way tie, how many votes would each of the four students have received?

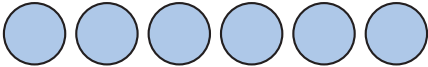
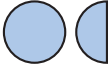
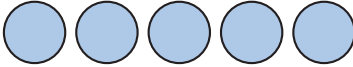

- \*30.** Use the pictograph below to answer parts **a** and **b**.  
(Inv. 5)

Animal	Typical Life Span (in years)
Moose	
Meadow mouse	
Gray squirrel	
Lion	

Key:  = 2 years

- a.** Write a number of years to represent each life span and order the life spans from greatest to least.
- b.**  **Connect** How does the average life span of a lion compare to the average life span of a meadow mouse?

**Early Finishers**  
Real-World Connection

One hundred twenty-three students were surveyed to find out if they wanted to go on a field trip to the ocean or to the museum. Of the students surveyed,  $\frac{2}{3}$  wanted to go to the ocean. The other students wanted to go to the museum.

- a.** How many students wanted to go to the ocean?
- b.** How many wanted to go to the museum?
- c.** Draw a circle graph to represent the results of the survey.

• **Schedules**

**Power Up**

**facts**

**mental math**

Power Up J

- a. **Estimation:** Estimate the cost of 10.17 gallons of gas at  $\$2.69 \frac{9}{10}$  per gallon.
- b. **Time:** How many years is half a century?
- c. **Fractional Parts:**  $\frac{1}{4}$  of \$80
- d. **Fractional Parts:**  $\frac{3}{4}$  of \$80
- e. **Percent:** 50% of  $\frac{1}{2}$
- f. **Measurement:** The high temperature was  $37^\circ$  Celsius, warm enough to go swimming. The nighttime low was  $23^\circ$  Celsius. What was the difference between the high and low temperatures?
- g. **Calculation:**  $\sqrt{64} \times \sqrt{64}$
- h. **Roman Numerals:** Write CL in our number system.

**problem solving**

Choose an appropriate problem-solving strategy to solve this problem. Jennifer wants to use 1-inch cubes to build a larger cube with edges 3 inches long. How many 1-inch cubes will she need?

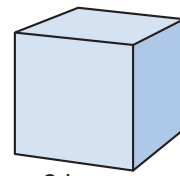

3 in.

**New Concept**

In this lesson we will use **schedules** to solve elapsed-time problems. A schedule is a list of times and events that shows when the events are planned to happen.

### Example 1

The schedule of events for the state track meet is shown in the program. Daphne qualified to run both the 300-meter low hurdles and the 200-meter dash. Her second race starts how many minutes after the start of her first race?

Time	Event
10:45 a.m.	400-meter relay
12:00 p.m.	100-meter high hurdles
12:15 p.m.	110-meter high hurdles
12:30 p.m.	100-meter dash
12:55 p.m.	400-meter dash
Intermission	
2:00 p.m.	1600-meter run
3:10 p.m.	300-meter low hurdles
3:25 p.m.	300-meter intermediate hurdles
3:40 p.m.	200-meter dash
4:10 p.m.	1600-meter relay

The 300-meter low hurdles race is scheduled for 3:10 p.m., and the 200-meter dash is scheduled for 3:40 p.m. If the events are held as scheduled, Daphne's second race will start **30 minutes** after the start of her first race.

**Discuss** Explain how to find the elapsed time.

One type of schedule is a travel itinerary. An **itinerary** lists starting locations and destinations along with planned departure and arrival times.

### Example 2

David planned a round-trip flight from Oklahoma City to Indianapolis and back to Oklahoma City. Here is David's flight itinerary:

Date	Depart	Arrive
Aug 22	6:11 a Okla. City	8:09 a Chicago
Aug 22	9:43 a Chicago	10:38 a Indianapolis
Aug 29	9:58 a Indianapolis	11:03 a St. Louis
Aug 29	12:04 p St. Louis	1:33 p Okla. City

#### Reading Math

On an airline schedule, *a* represents a.m. and *p* represents p.m.

**David needs to change planes on his way to Indianapolis and on his way back to Oklahoma City. In which cities does he change planes? How much time does David have in the schedule to make those plane changes?**

David's trip to Indianapolis has two legs: one from Oklahoma City to Chicago, with a scheduled arrival at 8:09 a.m., and one from Chicago to Indianapolis, with a scheduled departure at 9:43 a.m. So on David's trip to Indianapolis, he stops in **Chicago** and has **1 hour 34 minutes** in the schedule to change planes.

On David's return trip, the first leg has a scheduled arrival in **St. Louis** at 11:03 a.m. The second leg has a scheduled departure at 12:04 p.m. So David has **1 hour 1 minute** in the schedule to change planes in St. Louis.

### Activity

#### *Reading and Interpreting a Schedule*

Find a bus, train, or plane schedule online. Select a departure schedule and a return schedule, and print or record the schedules you find. Then write and answer two word problems about the schedule you choose.

### Lesson Practice

Refer to the track meet schedule in Example 1 to answer problems **a** and **b**.

- Tadeo qualified for the 1600-meter run. He usually starts warming up 45 minutes before the start of the race. At what time should Tadeo start his warm-up?
- D'Janelle is the leading qualifier in both the 100-meter and 200-meter dashes. How much time is scheduled between the start of those two events?

Use the flight itinerary in Example 2 to answer problems **c** and **d**.

- David's departure from Indianapolis is how many days after his arrival?
- Multiple Choice** For his flight to Indianapolis, David wants to get to the Oklahoma City airport one hour before the scheduled take-off. The drive from David's home to the airport usually takes half an hour. About what time should David leave home to drive to the airport?

**A** 4:00 a.m.    **B** 4:30 a.m.    **C** 5:00 a.m.    **D** 5:30 a.m.

- e. Luke rode the train from Chicago to Springfield. Here is the schedule for the train he boarded:

Station	Arrive	Depart
Chicago, IL		10:45 a.m.
Joliet, IL	11:55 a.m.	11:55 a.m.
Bloomington, IL	02:05 p.m.	02:35 p.m.
Springfield, IL	03:50 p.m.	03:55 p.m.
St. Louis, MO	05:40 p.m.	

How many hours and minutes are there from the time the train departs Chicago until the time it arrives in Springfield?

## Written Practice

*Distributed and Integrated*

- \* 1. **Represent** Jabari's dog weighs forty-five million, four hundred fifty-four thousand, five hundred milligrams. Use digits to write that number of milligrams.  
(52)
2. **Analyze** What is the total cost of 2 items at \$1.26 each and 3 items at 49¢ each, plus a total tax of 24¢?  
(49)
3. Flora rode her bike 2.5 miles from her house to the library. How far did she ride going to the library and back home?  
(73)
4. If  $4y = 20$ , then  $2y - 1$  equals what number?  
(18)
5. The arrow is pointing to what number on this scale?  
(27)

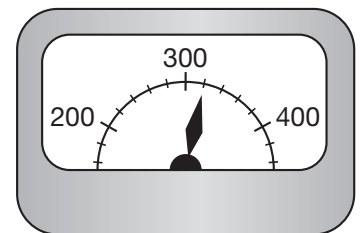

- \* 6. Fifteen of the 25 students in the class are boys.  
(97, 107)
- What percent of the students are boys?
  - What is the ratio of boys to girls in the class?

\*7. **Estimate** Find the sum of 12.7 and 8.167 by rounding both numbers to the nearest whole number before adding.  
(101)

\*8. Write the reduced fraction that equals 80%.  
(108)

\*9. Compare:  $50\%$   $\bigcirc$   $\frac{1}{2}$   
(108)

10.  $45^2$   
(78)

\*11. **Represent** Use words to name the number 76.345. Which digit is in the tenths place?  
(106)

12. A blue rectangle is drawn on the grid.  
(53, 72)

a. The perimeter of the rectangle is how many units?

b. The area of the rectangle is how many square units?

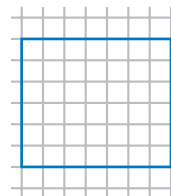

13.  $WX$  is 48 mm.  $XY$  is half of  $WX$ .  $YZ$  equals  $XY$ . Find  $WZ$ .  
(61)



14.  $2.386 + 1.2 + 16.25 + 10$   
(99)

\*15.  $4.2 - (3 - 0.45)$   
(24, 102)

16.  $\$37.05 \div 15$   
(94)

17. **Analyze** Write a fraction equal to  $\frac{1}{2}$  that has the same denominator as  $\frac{1}{6}$ . Then add the fraction to  $\frac{1}{6}$ . Remember to reduce your sum.  
(79, 81)

18.  $\frac{1}{2} \div \frac{2}{3}$   
(96)

19.  $\frac{3}{10} \times \frac{3}{10}$   
(76)

20.  $\frac{4}{11} + \frac{5}{11}$   
(41)

21.  $4\frac{5}{7} - \frac{1}{7}$   
(43)

22. Five sixths of the two dozen juice boxes were strawberry. How many of the juice boxes were strawberry?  
(46)



- \*23. Which vertical line is the line of symmetry and the line of reflection for this figure and its reflection?  
(105)

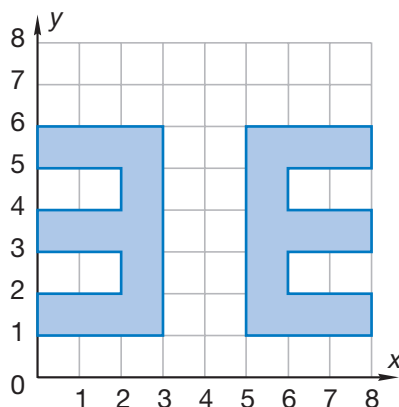

- \*24. This table shows how many students received certain scores out of a possible 20 on the test. Use the table to answer parts **a–d**.  
(Inv. 7, 84)

Test Results

Score	Number of Students
20	4
19	4
18	5
17	6
16	3
15	2

- Which score was made by the greatest number of students?
  - If 25 students took the test, how many students got fewer than 15 correct?
  - If the lowest score was 13, what was the range of the scores?
  - If all 25 scores were listed in order from greatest to least (20, 20, 20, 20, 19, 19, ...), which score would be in the middle of the list?
- \*25. What is the volume of a closet that is 5 feet wide, 2 feet deep, and 8 feet high?  
(103)

- \*26.  **Justify** Two feet is what percent of a yard? How do you know?  
(74, 107)

**\*27. a.** This star has how many lines of symmetry?  
(32, 105)

**b.** The star has how many sides? What kind of polygon is the star?



**28.** In the first soccer game of the season, Pablo scored one more goal than Chazz, and Chazz scored one more goal than D'Jon. D'Jon scored one goal. How many goals did Pablo score?  
(49)

**29.** Ruth is 1 year older than one half her sister's age. Ruth's sister is 14 years old. How old is Ruth?  
(49)

**30. Estimate** The highest and lowest temperatures ever recorded in the state of Vermont are shown on the thermometers below. When compared to the lowest temperature, how many degrees warmer is the highest temperature?  
(27, 98)

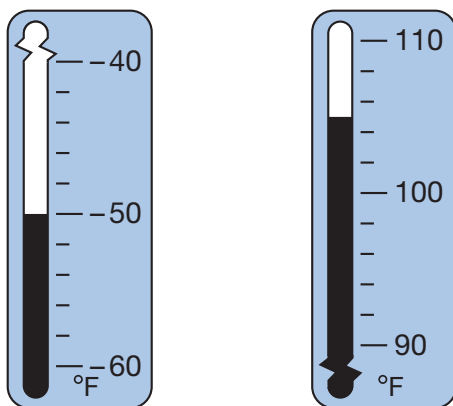

## Early Finishers

Real-World Connection

Use the table below to answer parts **a-c**.

Airline	Flight Time
Airline A	2 hours and 45 minutes
Airline B	3 hours and 15 minutes
Airline C	6 hours and 35 minutes

- Maria is taking Airline A, and her flight leaves at 9:00 a.m. What time will she arrive at her destination?
- How much longer is the flight time for Airline B than for Airline A?
- If Carol took Airline C and arrived at her destination at 10:00 p.m., what time did her flight leave?

## • Multiplying Decimal Numbers

### Power Up

#### facts

Power Up J

#### mental math

- Estimation:** Choose the more reasonable estimate for the weight of a pencil: 8 grams or 8 kilograms.
- Fractional Parts:**  $\frac{1}{8}$  of 80
- Fractional Parts:**  $\frac{3}{8}$  of 80
- Percent:** 25% of 80
- Money:** Haley bought a juice for \$1.89 and a snack bar for \$0.97. What was the total cost of the two items?
- Probability:** What is the probability that with one spin, the spinner will land on 2?

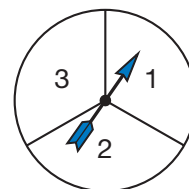

- Calculation:**  $\sqrt{81}$ ,  $\times 10$ ,  $- 2$ ,  $\div 2$ ,  $+ 1$ ,  $\div 5$
- Roman Numerals:** Write CV in our number system.

#### problem solving

Choose an appropriate problem-solving strategy to solve this problem. Austin wonders about how many seconds each day he is awake and about how many seconds he is asleep. He figures that he sleeps 9 hours each night. About how many seconds is Austin awake each day? About how many seconds is he asleep each day? Altogether, how many seconds are in one day? Explain your reasoning.

### New Concept

What is one tenth of one tenth? We will use pictures to answer this question.

The first picture at right is a square. The square represents one whole, and each column is one tenth of the whole. We have shaded one tenth of the whole.

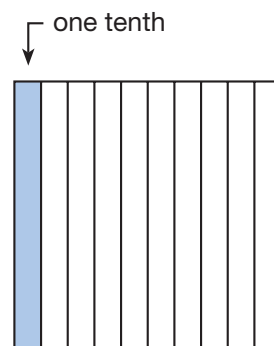

To find one tenth of one tenth, we divide each tenth into ten parts. In the second picture at right, we show each column divided into ten parts. One small square is shaded. We have shaded one tenth of one tenth of the whole. The shaded part is **one hundredth** of the whole.

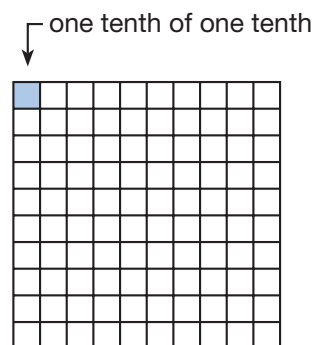

When we find one tenth of one tenth, we are multiplying. Here we show the problem written as a multiplication equation:

$$\frac{1}{10} \times \frac{1}{10} = \frac{1}{100}$$

We can also write the same problem using decimal numbers, like this:

$$\begin{array}{r} 0.1 \\ \times 0.1 \\ \hline 0.01 \end{array}$$

When we set up a decimal multiplication problem, we do not line up the decimal points as we do in addition and subtraction. We just set up the problem as though it were a whole-number problem and then multiply. To place the decimal point in the answer, we first count the total number of decimal places in both factors. Then we insert a decimal point in the answer so that it has the same total number of decimal places as the factors.

**Copy** and **study** the following examples and solutions:

$$\begin{array}{r} 1 \\ 0.12 \\ \times 6 \\ \hline 0.72 \end{array} \begin{array}{l} \text{2 digits to right of decimal point} \\ \text{0 digits to right of decimal point} \\ \text{-----} \\ \text{2 digits to right of decimal point} \end{array}$$

### Reading Math

You can count the decimal places because fractions and decimals are related.

tenths  $\times$  ones = tenths:

$$\frac{1}{10} \times 3 = \frac{3}{10}$$

tenths  $\times$  tenths = hundredths:

$$\frac{3}{10} \times \frac{5}{10} = \frac{15}{100}$$

tenths  $\times$  hundredths = thousandths:

$$\frac{3}{10} \times \frac{7}{100} = \frac{21}{1000}$$

$$\begin{array}{r} 1 \\ 25 \\ \times 0.3 \\ \hline 7.5 \end{array}$$

0 digits to right of decimal point  
1 digit to right of decimal point  
1 digit to right of decimal point

$$\begin{array}{r} 4 \\ 0.15 \\ \times 0.9 \\ \hline 0.135 \end{array}$$

2 digits to right of decimal point  
1 digit to right of decimal point  
3 digits to right of decimal point

The rule for multiplying decimal numbers is “Multiply, then count.” We multiply the digits; then we count the total number of decimal places in the factors. Then, starting from the right side of the answer, we count over that many digits and mark the decimal point.

In the chart below we have summarized the rules of decimal arithmetic for adding, subtracting, and multiplying:

Decimals Chart

Operation	+ or -	$\times$
Memory cue	line up . $\pm$ . .	$\times$ ; then count .- $\times$ .- .-.
You may need to ...		
<ul style="list-style-type: none"> <li>Place a decimal point on the end of whole numbers.</li> <li>Fill empty places with zero.</li> </ul>		

### Lesson Practice

Multiply:

a.  $0.3$   
 $\times 4$

b.  $3$   
 $\times 0.6$

c.  $0.12$   
 $\times 12$

d.  $1.4$   
 $\times 0.7$

e.  $0.3 \times 0.5$

f.  $1.2 \times 3$

g.  $1.5 \times 0.5$

h.  $0.25 \times 1.1$

i. Compare:  $\frac{3}{10} \times \frac{3}{10} \bigcirc 0.3 \times 0.3$

j. What is the area of this square?

0.8 cm



### Written Practice

*Distributed and Integrated*

\*1. Copy the decimals chart in this lesson.

(109)

\*2. Forty of Lauren's 50 answers were correct. What percent of Lauren's answers were correct?  
(107)

\*3. Compare:  $\frac{1}{10} \times \frac{1}{10} \bigcirc 0.1 \times 0.1$   
(109)

4. What time is 35 minutes before midnight?  
(28)

5. **Represent** Use digits to write the decimal number one hundred one and one hundred one thousandths.  
(68)

6. **Analyze** Three small blocks of wood are balanced on one side of a scale with a 100-gram weight and a 500-gram weight on the other side. If each block weighs the same, what is the weight of each block?  
(50)

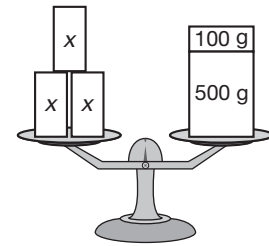

7. What are the first five multiples of 10?  
(15)

\*8. **Explain** The total cost of an item Lucie purchased online was \$23.20, which included a shipping charge of \$6.95. What is a reasonable estimate of the cost of the item, not including shipping? Explain your answer.  
(104)

9. A rectangle is drawn on this grid.  
(53, 72)

- How many units is the perimeter of the rectangle?
- How many square units is the area of the rectangle?

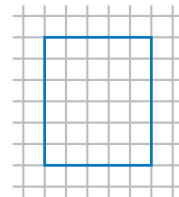

10. a. Write the reduced fraction equal to 10%.  
(71, 90)

b. Write the reduced fraction equal to 20%.

11.  $32.3 + 4.96 + 7.5 + 11$   
(99)

\*12.  $1 - (1.36 - 0.8)$   
(24, 102)

\*13.  $12 \times 1.2$   
(109)

\*14.  $0.15 \times 0.9$   
(109)

\*15.  $0.16 \times 10$   
(109)

16.  $13m = 3705$   
(26, 94)

17.  $6 \overline{) \$8.76}$   
(26)

18.  $980 \div 28$   
(94)

19.  $1\frac{3}{5}$   
(41)  
 $+ 1\frac{1}{5}$   

---

20.  $4\frac{3}{10}$   
(91)  
 $+ 1\frac{2}{10}$   

---

21.  $4\frac{3}{10}$   
(41)  
 $- 1\frac{2}{10}$   

---

22. **Analyze** Write fractions equal to  $\frac{2}{3}$  and  $\frac{1}{2}$  that have denominators of 6. Then subtract the smaller fraction from the larger fraction.  
(79)

23.  $\frac{3}{10} \times \frac{1}{3}$   
(90)

24.  $\frac{3}{4} \div \frac{3}{5}$   
(96)

25.  $\frac{3}{10} \div 3$   
(96)

26. a. The floor of a room that is 12 feet wide and 15 feet long will be covered with tiles that are 1 foot square. How many tiles are needed?  
(53, 72)

b. Baseboard will be nailed around the edge of the floor described in part a. How many feet of baseboard are needed?

\*27. What is the volume occupied by a refrigerator with the dimensions shown?  
(103)

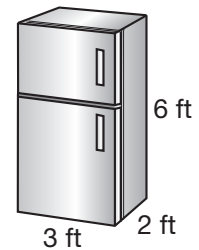

\*28. Below is a schedule of one day's soccer matches during the 2000 Summer Olympics in Australia. Refer to this schedule to answer parts a and b.  
(108)

Sydney Time	Event	Venue
5:00 p.m.–7:00 p.m.	Women: Australia vs. Germany	Bruce Stadium, Canberra
5:00 p.m.–7:00 p.m.	Women: Sweden vs. Brazil	Melbourne Cricket Ground
6:30 p.m.–8:30 p.m.	Men: Nigeria vs. Honduras	Hindmarsh Stadium
7:00 p.m.–9:00 p.m.	Men: Cameroon vs. Kuwait	Brisbane Cricket Ground
8:00 p.m.–10:00 p.m.	Men: USA vs. Czech Republic	Bruce Stadium, Canberra
8:00 p.m.–10:00 p.m.	Men: Australia vs. Italy	Melbourne Cricket Ground

a. How much time is allowed in the schedule for each soccer game?

b. How much time is allowed between games when more than one game is played at a venue?

\*29. <sup>(49)</sup> A theater is showing a movie twice each evening. The movie is 110 minutes long and the elapsed time between showings is 40 minutes. If the first showing of the movie begins at 6:45 p.m., when does the last showing begin?

\*30. <sup>(Inv. 6)</sup> **Formulate** The average monthly temperature in Seattle, Washington during the first five months of the year is shown in the table. Display the data in a line graph. Then write two questions that can be answered using your graph.

**Average Monthly Temperature  
Seattle, WA**

Month	Temperature (°F)
January	41
February	43
March	46
April	50
May	56

**Early  
Finishers**  
*Real-World  
Connection*

There are 0.75 ounces of pure gold per ounce of 18-karat gold.  
There are 0.25 ounces of other metals per ounce.

- How many ounces of pure gold are there in an 18-karat gold bracelet that weighs 2.8 ounces?
- What are the steps used for multiplying decimals?



## • Multiplying Decimal Numbers: Using Zeros as Placeholders

### Power Up

#### facts

Power Up J

#### mental math

- Estimation:** Estimate the product of  $8\frac{3}{4}$  and  $5\frac{1}{4}$  by rounding each mixed number to the nearest whole number and then multiplying.
- Measurement:** How many centimeters are in  $5\frac{1}{2}$  meters?
- Number Sense:** Simplify the fractions  $\frac{6}{9}$ ,  $\frac{12}{9}$ , and  $\frac{24}{9}$ .
- Number Sense:**  $1 - \frac{5}{8}$
- Time:** How many minutes are in  $\frac{1}{4}$  of an hour?
- Geometry:** If the perimeter of a square is 36 cm, what is the length of each side?
- Calculation:**  $\frac{1}{6}$  of 30,  $\times 5$ ,  $+ 2$ ,  $\div 3$ ,  $\times 4$ ,  $\div 6$
- Roman Numerals:** Write XLV in our number system.

#### problem solving

Choose an appropriate problem-solving strategy to solve this problem. Ricardo scored 84 and 92 in his first two games. What is his average score for the two games? What does Ricardo need to score in the next game to have a three-game average of 90? Explain how you arrived at your answer.

### New Concept

When we multiply decimal numbers, we follow the rule “Multiply, then count.” We count the total number of decimal places in the factors. Then, starting from the right-hand end of the product, we count over the same number of places and mark the decimal

point.

Sometimes there are more decimal places in the factors than there are digits in the product. Look at this problem, for example:

$$\begin{array}{r} 0.3 \\ \times 0.3 \\ \hline .9 \end{array}$$

} There are two digits to the right of the decimal points in the factors. So we count over two places in the product, but there is only one digit.

### Reading Math

You can check the answer by thinking tenths  $\times$  tenths = hundredths. The product must be written as hundredths.

To complete the multiplication, we use a rule from the bottom of the decimals chart in Lesson 109. We “fill empty places with zero.” Then we add a zero to the left of the decimal point.

$$\begin{array}{r} 0.3 \\ \times 0.3 \\ \hline 0.09 \end{array}$$

Add a zero to the left of the decimal point.  $\rightarrow$   $0.09$

$\uparrow$  Fill the empty place with zero.

Changing the problem  $0.3 \times 0.3$  to a fraction problem may help us understand why we use zeros as placeholders. Since  $0.3$  equals  $\frac{3}{10}$ , we may write the multiplication problem like this:

$$\frac{3}{10} \times \frac{3}{10} = \frac{9}{100}$$

The product  $\frac{9}{100}$  may be written as the decimal number  $0.09$ .

### Example

**Multiply:**  $0.12 \times 0.3$

We set up the problem as though it were a whole-number problem. We follow the rule “Multiply, then count.” We fill empty places with zero and get the product **0.036**.

$$\begin{array}{r} 0.12 \\ \times 0.3 \\ \hline 36 \\ .036 \end{array}$$

3 digits to the right of the decimal points

Count over 3 places; fill the empty place with zero.

**Justify** Explain how you can check the answer.

### Lesson Practice

Multiply:

a.  $\begin{array}{r} 0.25 \\ \times 0.3 \\ \hline \end{array}$

b.  $\begin{array}{r} 0.12 \\ \times 0.12 \\ \hline \end{array}$

c.  $\begin{array}{r} 0.125 \\ \times 0.3 \\ \hline \end{array}$

d.  $\begin{array}{r} 0.05 \\ \times 0.03 \\ \hline \end{array}$

e.  $0.03 \times 0.3$

f.  $3.2 \times 0.03$

g.  $0.6 \times 0.16$

h.  $\begin{array}{r} 0.12 \times 0.2 \\ 0.1 \\ 0.12 \end{array}$

i.  $\begin{array}{r} 0.01 \times \\ 0.07 \times \end{array}$

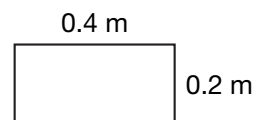

k. What is the area of this rectangle?

- \* 1. **Estimate** To estimate the product of 5.375 and 3.8, round both numbers to the nearest whole number before multiplying.  
(104)
- \* 2. The football team played 10 games and won 5. What percent of the games did the team win?  
(107)
3. a. Write the reduced fraction that equals 30%.  
(71, 90)  
b. Write the reduced fraction that equals 40%.
- \* 4. **Analyze** Two fifths of the 100 passengers stayed in the subway cars until the last stop. How many of the 100 passengers got off the subway cars before the last stop?  
(46, 60)
5. a. Name the length of this segment as a number of centimeters and as a number of millimeters.  
(66, 74)

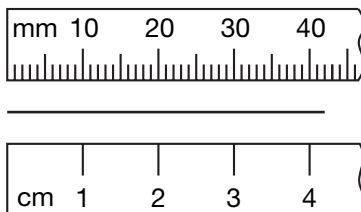

- b. If the segment were cut into thirds, each third would be how many centimeters long?  
(45, 74)
6. **Analyze** Write fractions equal to  $\frac{5}{6}$  and  $\frac{1}{4}$  that have denominators of 12. Then add the fractions. Remember to convert the sum to a mixed number.  
(75, 79)
7. A hexagon is drawn on the grid.  
(53, 72)
- a. How many units is the perimeter of this hexagon?
- b. How many square units is the area of the hexagon?

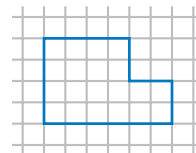

8. a. **Conclude** In rectangle  $ABCD$ , which segment is parallel to  $\overline{AB}$ ?

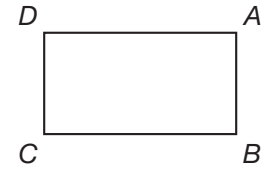

b. **Conclude** In rectangle  $ABCD$ , which two segments are perpendicular to  $\overline{AB}$ ?

9. **Represent** Write 0.375 as an unreduced fraction. Then use words to name the number.

\*10.  $6 - 4.32$

\*11.  $0.12 \times 0.11$

\*12.  $0.04 \times 0.28$

\*13.  $10 \times 0.25$

14.  $19x = 3705$

15.  $30^2$

16.  $\frac{5}{13} + \frac{10}{13}$

17.  $\frac{11}{12} - \frac{7}{12}$

18.  $1 \times \frac{5}{6}$

19.  $2 \div \frac{5}{6}$

20.  $\frac{5}{6} \div 2$

\*21. **Interpret** Students in a math class were given a choice of one out of 4 math projects labeled  $A$ ,  $B$ ,  $C$ , and  $D$  to complete. This circle graph shows the percent of students in the class who chose each project. Use this graph to answer parts **a–c**.

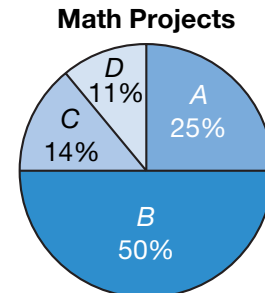

- Add the percents shown on the graph. What is the total?
- Which project was chosen by  $\frac{1}{4}$  of the students?
- If the teacher selects a project without looking, what is the probability that the project will be from group  $B$ ?

\*22. a. **Conclude** Draw the next term of this sequence:

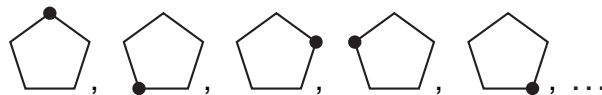

b. What transformation changes the terms of the sequence in part **a**?

23. At Felipe's school, class begins at 7:55 a.m. and ends at 3:10 p.m.  
(49) At Natalie's school, class begins at 8:15 a.m. and ends at 3:25 p.m.  
 Whose school day is longer, and how much longer is it?

- \*24. The three runners below received medals in the men's 100-meter run  
(69, 73) at the 2000 Summer Olympic Games in Sydney, Australia. Refer to this information to answer parts **a** and **b**.

Runner	Country	Time
Ato Bolden	Trinidad and Tobago	9.99 seconds
Maurice Greene	United States	9.87 seconds
Obadele Thompson	Barbados	10.04 seconds

- a. Write the last names of the runners in the order of their finish, starting with the first-place runner.
- b. The first-place runner ran how many seconds faster than the third-place runner?
25. Write your age, and write the age of one of your family members that  
(25) has an age different than your age. How many common factors do the two numbers you wrote have?
- \*26. How many prime numbers are greater than 20 but less than 25?  
(80) How many composite numbers are greater than 20 but less than 25?
27. A recipe for a vegetable medley calls for  $\frac{2}{3}$  of a pound of red peppers  
(41) and  $\frac{2}{3}$  of a pound of green peppers. In simplest form, how many pounds of peppers does the recipe call for?
28. On Sunday evening, Jorge spent  $\frac{1}{4}$  of an hour talking on the telephone.  
(63) He spent the remainder of the hour doing homework. What fraction of an hour did Jorge spend doing homework on Sunday evening?

29.  **Explain** Jessie estimated the quotient of  $277 \div 4$  to be about 70.  
(31) Did Jessie make a reasonable estimate? Explain why or why not.

- \*30. **Predict** The food-service staff of a high school cafeteria is making  
(75, 91) 6 batches of oatmeal cookies. Use the table below to help you find how many cups of flour will be used.

Batches of oatmeal cookies	1	2	3	4
Cups of flour	$2\frac{1}{4}$	$4\frac{1}{2}$	$6\frac{3}{4}$	9

Focus on

• Scale Drawings

A **scale drawing** is a picture or diagram of a figure that has the same shape as the figure but is a different size. Below is a scale drawing of the bedroom shared by Jane and Zoe. Notice the legend to the right of the picture. It shows that 1 inch in the picture represents 8 feet in the actual bedroom. The equivalence 1 in. = 8 ft is called the *scale*. A **scale** is a ratio that shows the relationship between a scale drawing (or model) and the actual object.

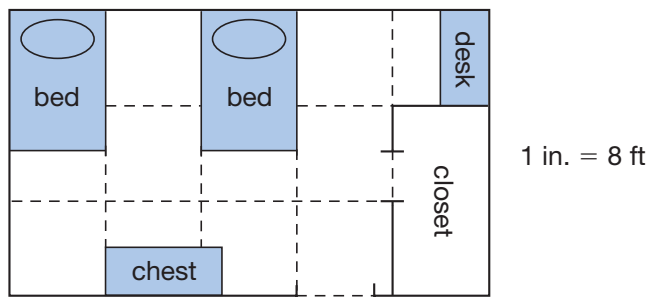

Since 1 in. in the picture represents 8 ft in the actual bedroom, we also know the following relationships:

$$\frac{1}{2} \text{ in.} = 4 \text{ ft (since } \frac{1}{2} \times 8 = 4 \text{)}$$

$$\frac{1}{4} \text{ in.} = 2 \text{ ft (since } \frac{1}{4} \times 8 = 2 \text{)}$$

$$\frac{1}{8} \text{ in.} = 1 \text{ ft (since } \frac{1}{8} \times 8 = 1 \text{)}$$



If we measure the picture, we find that it is  $2\frac{1}{2}$  in. ( $\frac{20}{8}$  in.) long and  $1\frac{1}{2}$  in. ( $\frac{12}{8}$  in.) wide. This means that the actual bedroom is 20 ft long and 12 ft wide.

1. What is the actual distance between the beds?
2. What is the actual length and width of the closet?
3. **Analyze** What is the actual area of the entire room? What is the area if you subtract the area of the closet?
4. What is the actual length and width of the beds?
5. What is the actual length and width of the desk?
6. **Analyze** Identify an object in the picture that is about 5 ft long.

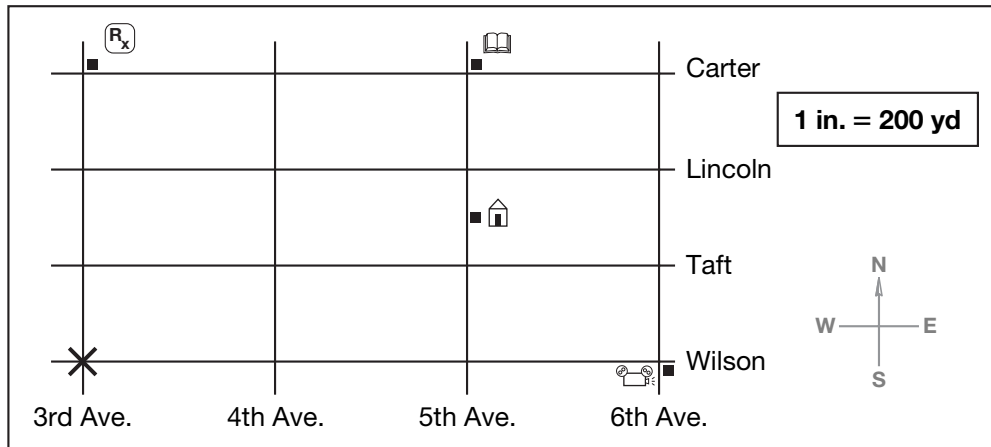
Andrew is on the corner of Wilson and 3rd Avenue. His position is marked by the “X” on the scale drawing below. Andrew’s house, which is halfway between Taft and Lincoln on 5th Avenue, is represented by the following symbol: .



For problems 7–11, assume Andrew travels only along the streets shown above.

7. How far is Andrew from the movie theatre () at the corner of Wilson and 6th Avenue?
8. How far is he from the drugstore () on the corner of Carter and 3rd Avenue?
9. **Analyze** How far is he from the library () on the corner of Carter and 5th Avenue? Describe the three shortest routes he could take to get to the library.
10. How far is Andrew from his house?
11. **Estimate** Measure the straight-line distance in inches between Andrew’s starting point and the corner of Carter and 5th Avenue. From this measurement, estimate the actual straight-line distance in yards.

A familiar type of scale drawing is a map. On a certain map of New York City, the scale is 2 in. = 1 mi. This means that 2 inches on the map represents 1 mile of actual distance.

12. What length on the map corresponds to an actual distance of 3 miles? What length on the map corresponds to an actual distance of  $\frac{1}{2}$  mile?
13. What fraction of a mile corresponds to  $\frac{1}{2}$  in. on the map? What fraction of a mile is represented by  $1\frac{1}{2}$  in.?
14. What length on the map represents an actual distance of 5 miles?

## Investigate Further



- Draw a scale picture of the kitchen in your house. Include the stove, refrigerator, and other important items. Use the scale 1 in. = 2 ft.
- Estimate** Find a street map of your city or a nearby city. Using the legend on the map, estimate the shortest distance between your school and a park of your choice. Use the road system rather than a straight-line distance, and describe the route you chose.
- We can make **scale models** of 3-dimensional figures. Model trains and action figures are examples of scale models. Using cardboard and glue or tape, make a scale model of the barn below. Use the scale 1 in. = 8 ft. Note that the front and the back of the barn are pentagons.

